

**SERVICE MANUAL
&
PARTS LIST**

SKYLINE S5

INDEX

Changing external parts

Face cover.....	1
Belt cover	1
Top cover	2
Machine base.....	3
Base cover	3
Bed cover	3
Free arm cover	4
Front cover	5
Rear cover.....	6

Replacing electronic components

Printed circuit board A.....	7
Printed circuit board F.....	8
Switching power supply unit.....	9
DC motor.....	10
Thread tension unit	11

Mechanical adjustment

Feed dog height	12
Needle drop position	13
Presser bar height.....	14
Hook timing	15
Needle bar height.....	16
Clearance between needle and tip of the rotary hook	17-18
Presser bar lifter switch position adjustment.....	19
Backlash between hook drive gear and lower shaft gear.....	20
Upper shaft shield plate position	21
Upper thread tension.....	22
Needle threader plate.....	23
Buttonhole lever adjustment.....	24
Thread cutter.....	25
Solenoid position adjustment	26
Stretch stitch feed balance	27
Needle plate switch	28-29

Diagnosis test	30-35
-----------------------------	-------

PARTS LIST	36-57
-------------------------	-------

Changing external parts

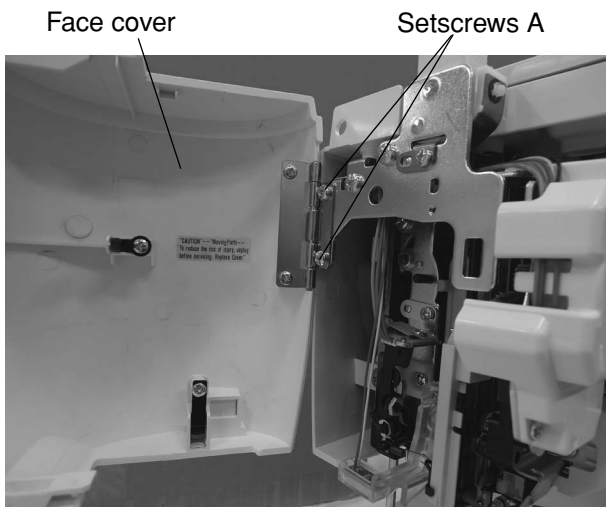

Face cover

To remove:

1. Remove the setscrews A.
Remove the face cover.

To attach:

1. Follow the above procedure in reverse.

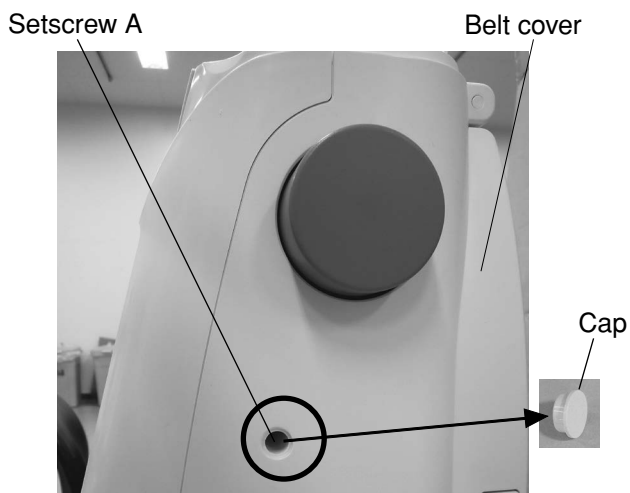

Belt cover

To remove:

1. Remove the cap and setscrew A and B.
2. Loosen the setscrew C.
3. Remove the belt cover from the main body.
Be careful not to pull the relay connector.
4. Disconnect the relay connector between the printed circuit board A and the thread cutter switch socket.
5. Remove the belt cover.

To attach:

1. Follow the above procedure in reverse.

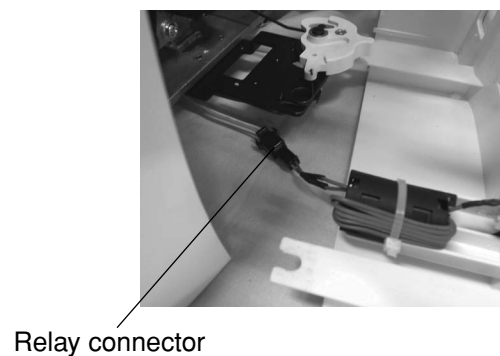
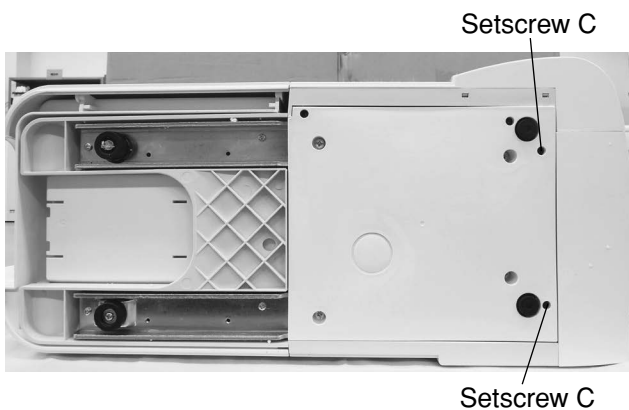
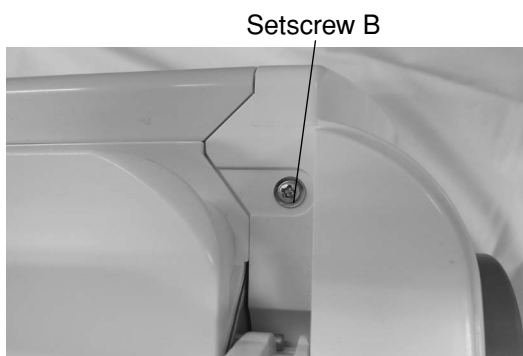

Changing external parts

Fig. 1

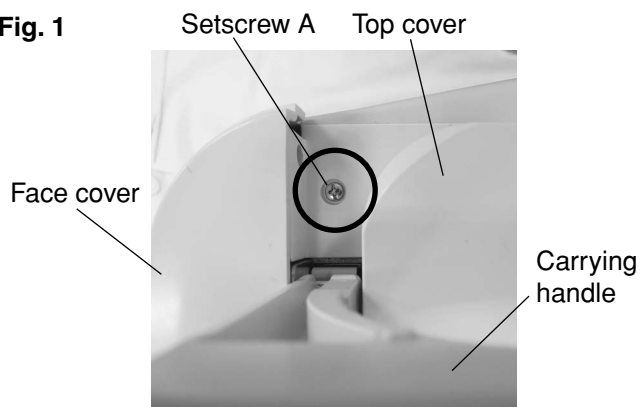

Top cover

To remove:

1. Raise the carrying handle and remove the setscrew A.
2. Open the top cover. Pull out the flange plate from the bobbin winder spindle (see fig. 2).
3. Remove the setscrews B and C.
4. Open the face cover. Close the top cover. Raise the carrying handle. Pull the top cover toward you to remove it (see fig. 4).

Fig. 2

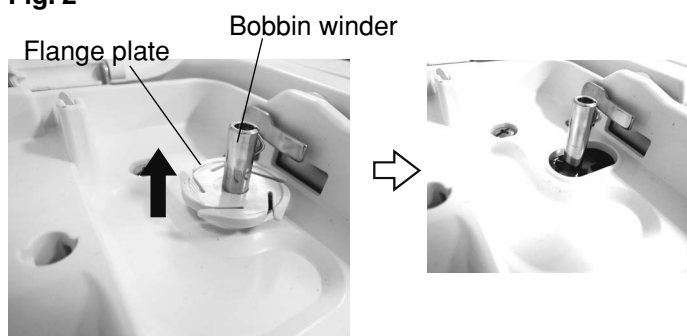

To attach:

1. Follow the above procedure in reverse. To attach the flange plate, put the flange plate into the bobbin winder, and push the flange plate down. Turn the flange plate until it snaps to the pin of the bobbin winder spindle (see fig. 5).

Fig. 3



Fig. 4



Fig. 5

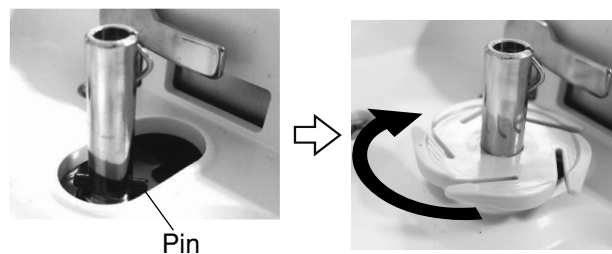

Changing external parts

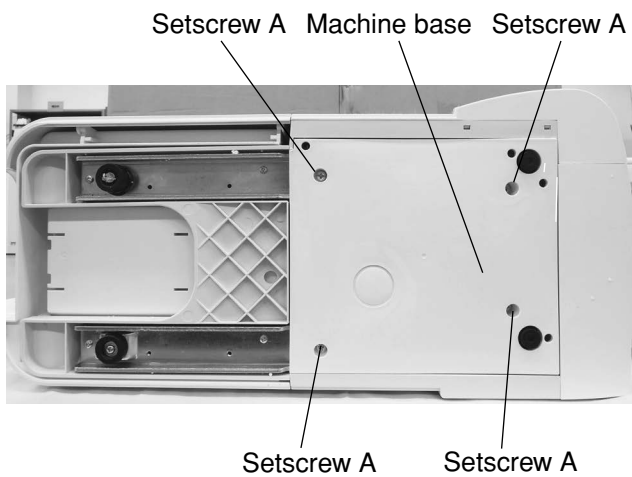

Machine base

To remove:

1. Remove the setscrews A.
2. Remove the machine base.

To attach:

1. Follow the above procedure in reverse.

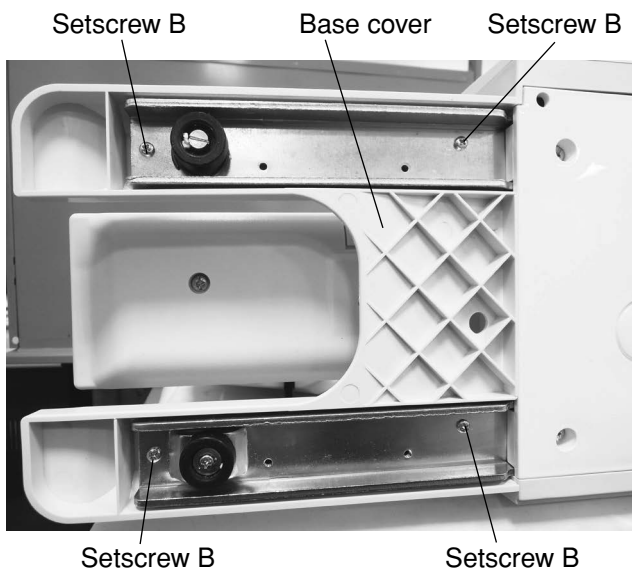

Base cover

To remove:

1. Remove the setscrews B.
2. Remove the base cover.

To attach:

1. Follow the above procedure in reverse.

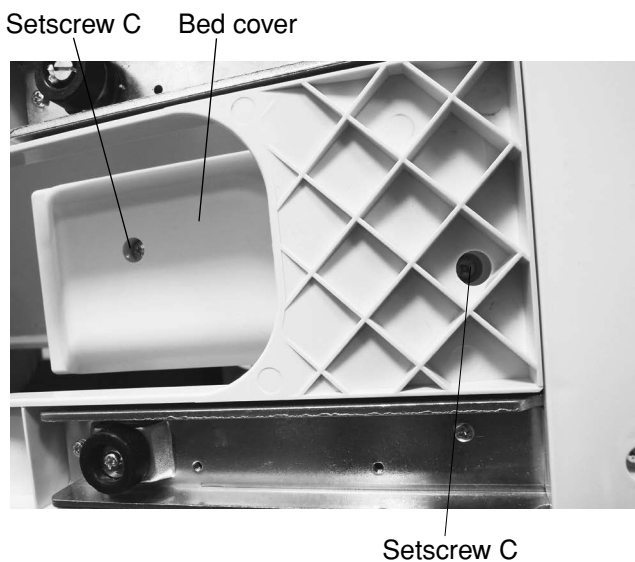

Bed cover

To remove:

1. Remove the setscrews C.
2. Remove the bed cover.

To attach:

1. Follow the above procedure in reverse.

Changing external parts

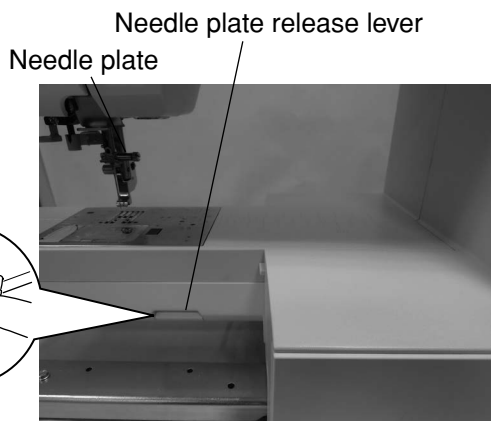

Free arm cover

To remove:

1. Remove the machine base and base cover (see page 3).
Press the needle plate release lever to remove the needle plate.
Remove the bed cover.

2. Remove the pin.
Loosen the setscrew.

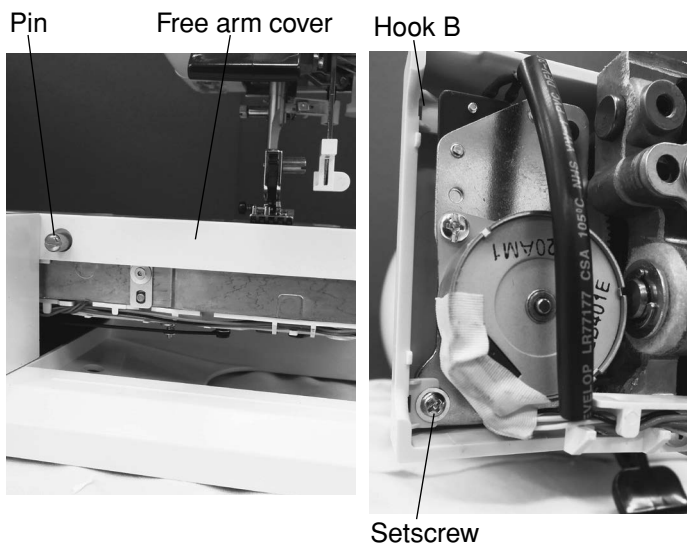

3. Unlock the hook A (inside of the machine base) and B (edge of the free arm).
4. Slide the free arm cover to the left.
Remove the free arm cover while removing the 3 hooks and 2 tabs from the free arm.

To attach:

1. Follow the above procedure in reverse.

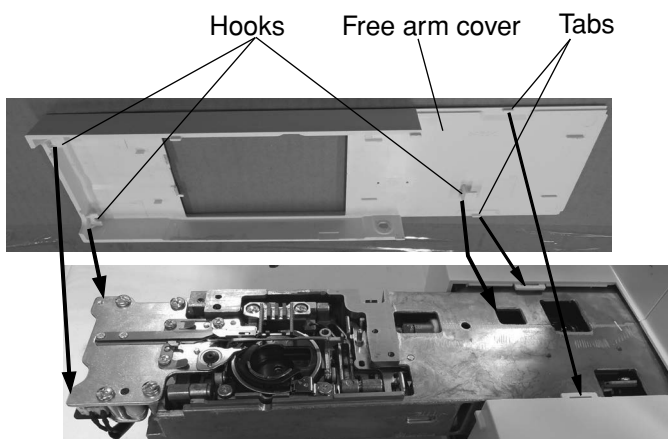
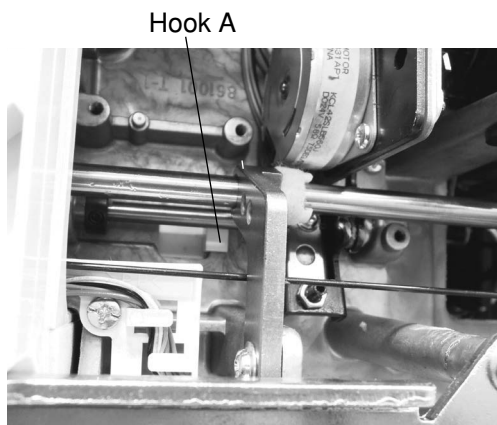

Changing external parts

Setscrew A

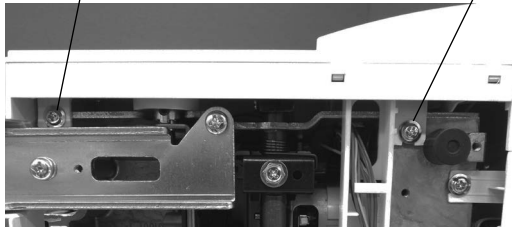

Setscrew A



Setscrew B

Setscrew C



Setscrew D

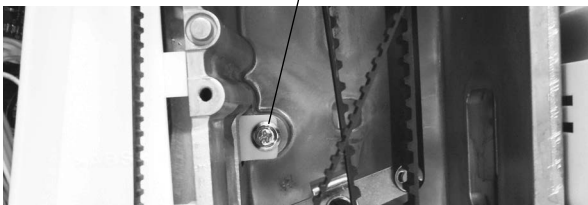

Hooks



Hole A

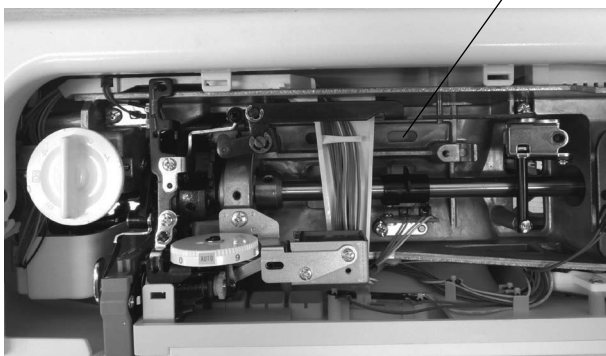

Front cover

To remove:

1. Remove the top cover, belt cover, base cover, machine base and free arm cover (see pages 1-4).
2. Loosen the setscrews A (inside of the machine base).

3. Remove the setscrew B.

4. Loosen the setscrew C (inside of the face cover).

5. Loosen the setscrew D (inside of the belt cover).

6. Unlock the hooks from the front cover. Remove the connectors from the circuit board A. While pushing the rear cover through the hole A with a screwdriver, remove the front cover.

To attach:

Follow the above procedure in reverse. Refer to page 7 for locating connector posts.

Changing external parts

Fig. 1

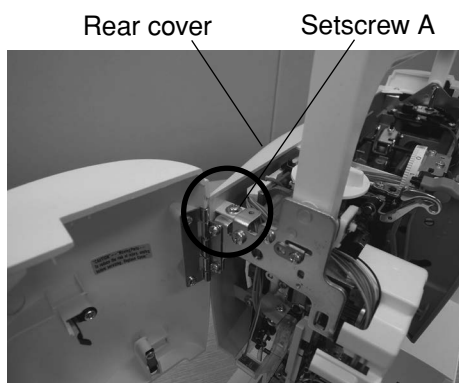

Setscrew B



Rear cover

To remove:

1. Lower the presser foot.
2. Remove the belt cover, top cover and base cover (see pages 1, 2 and 3).
3. Loosen the setscrews A and B (see fig. 1). Remove the setscrews C (see fig. 2)
4. Push the rear cover from the holes D and E with a screwdriver to remove the hook of rear cover.
5. Remove the rear cover.

To attach:

1. Follow the above procedure in reverse.

Fig. 2

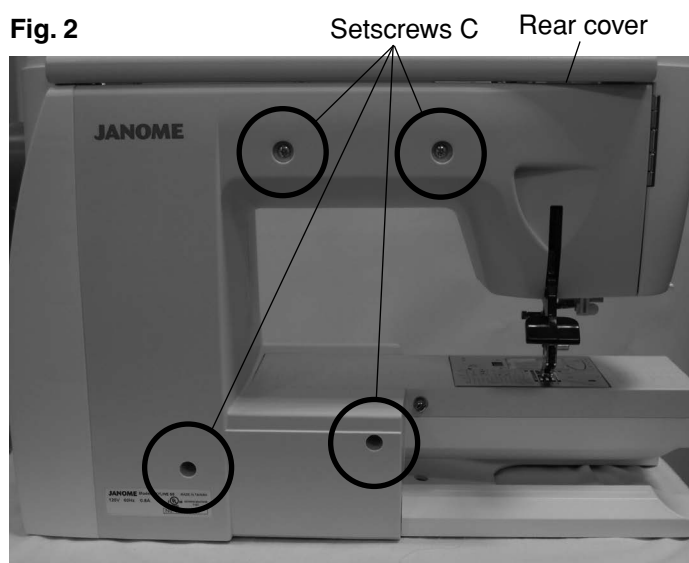
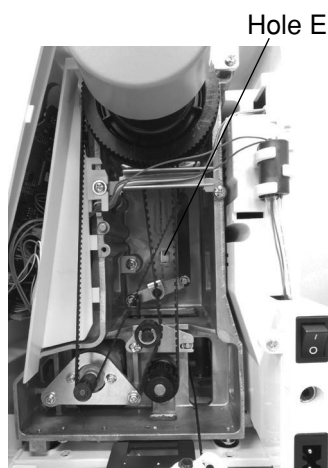

Fig. 3



Fig. 4



Replacing electronic components



Printed circuit board A

NOTE:

Do not disconnect the connectors by pulling on cord. To disconnect the connectors, grasp the connector, not the cord.

To remove:

1. Remove the front cover (see page 5).
2. Grasp the connector directly with your fingers and pull. Do not pull the lead wire, as this may damage the contact sleeve inside of the connector. Remove the setscrews and printed circuit board A.

To attach:

1. Follow the above procedure in reverse. Be sure that the connector post on the printed circuit board to which it is connected. Position the connector correctly, then push it straight down until it locks in place.

Printed circuit board A connection

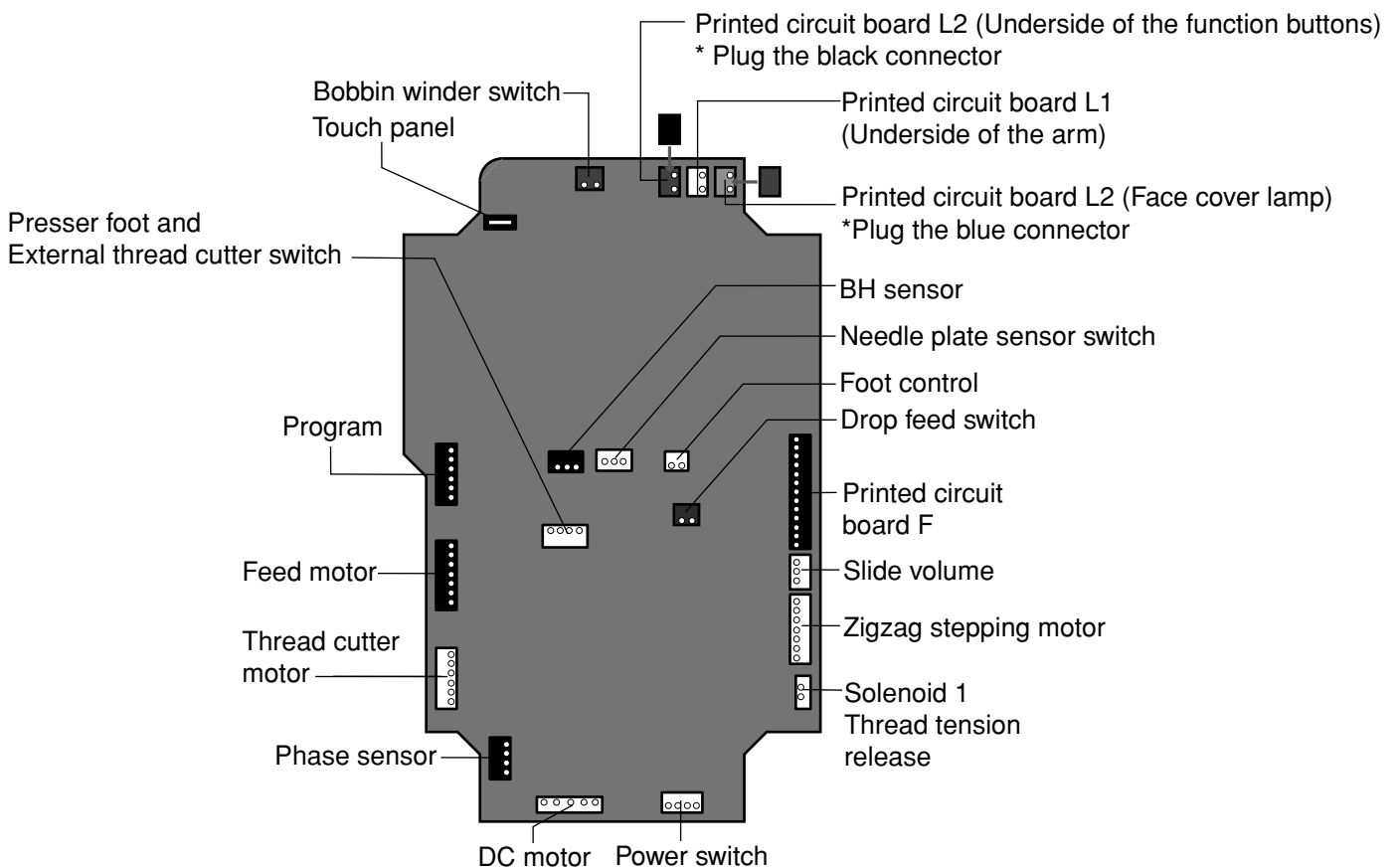

NOTE:

The colors of the connector posts for printed circuit board L2 do not match with the colors of the connectors to be inserted. Be careful when you insert the connectors into the connector posts.

Replacing electronic components

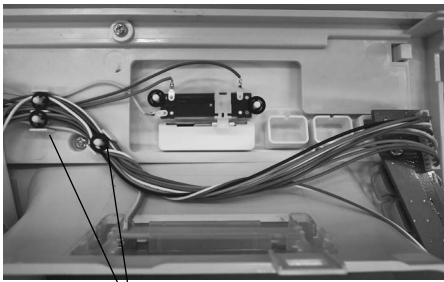

CS rings

Printed circuit board F

To remove:

1. Remove the front cover (see page 5).
2. Disconnect the connector from the printed circuit board A (see page 7).
3. Remove the CS rings.
4. Remove the setscrews, and the printed circuit board F.

To attach:

1. Follow the above procedure in reverse.

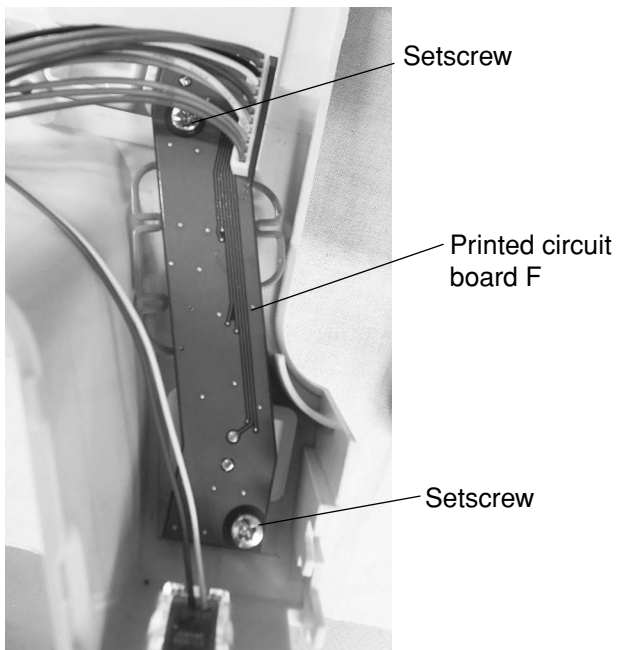

Setscrew

Printed circuit board F

Setscrew

Replacing electronic components

Switching power supply unit



Switching power supply unit

To remove:

1. Remove the belt cover, the top cover and the front cover (see pages 1, 2 and 5).
2. Loosen the setscrew A. Remove the cord guide plate. (see fig. 1)
3. Disconnect the switching power supply connector from the switching power supply unit. (see fig. 2)
4. Remove the foot control connector from the printed circuit board A. (see fig. 2) (see page 7)
5. Remove the setscrews B, and switching power supply. (see fig. 2)

To attach:

1. Follow the above procedure in reverse.

Fig. 1

Cord guide plate
Setscrew A

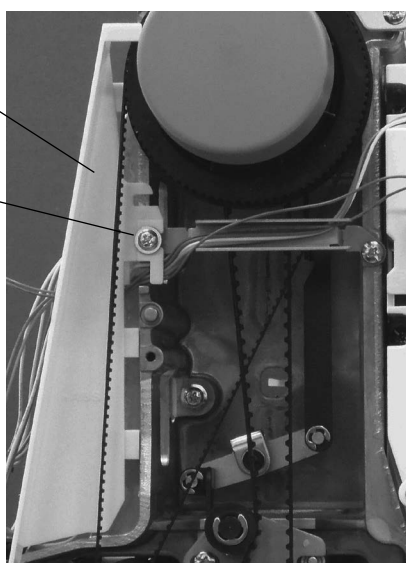

Fig. 2

Switching power supply connector

Setscrews B

Foot control connector (cord)

Setscrew B

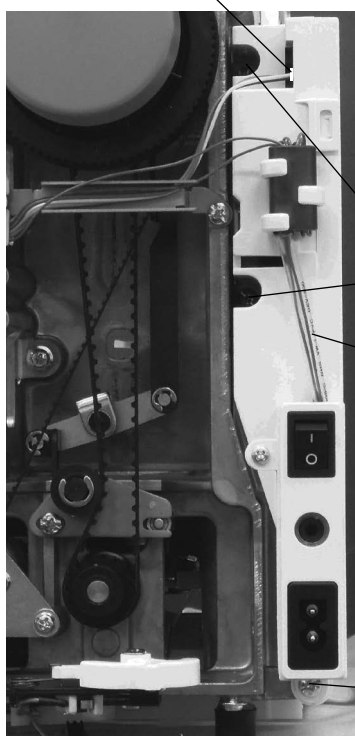

Replacing electronic components

DC motor

To remove:

1. Remove the belt cover, the top cover and the front cover (see pages 1, 2 and 5).
2. Disconnect the DC motor connector from the printed circuit board A (see page 7).
3. Remove the motor belt.
4. Remove the setscrews (2 pcs), and the DC motor.

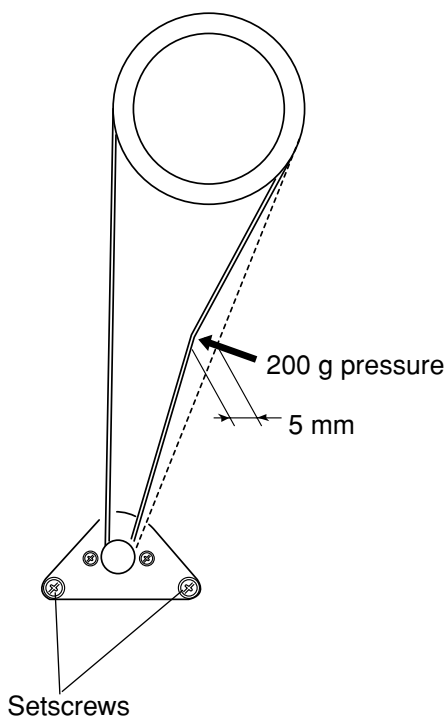
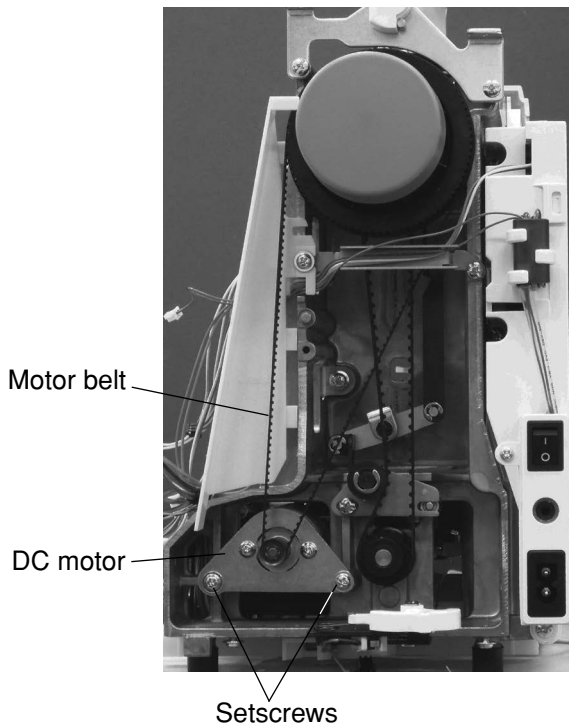

To attach:

1. Attach the DC motor. Tighten the setscrews temporarily.
2. Adjust the motor belt deflection to about 5 mm by pressing the middle of the motor belt with your finger with approximately 200 grams of pressure.
3. Tighten the setscrews securely.
4. Plug the DC motor connector to the printed circuit board A (see page 7).
5. Attach the front cover, the top cover and the belt cover.

Replacing electronic components

Fig. 1

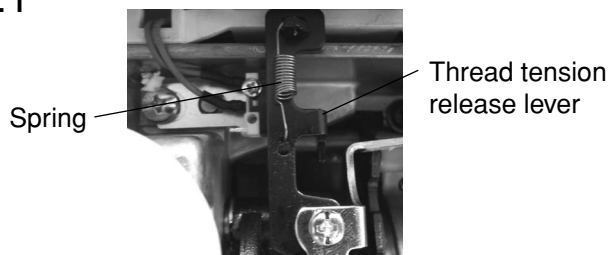
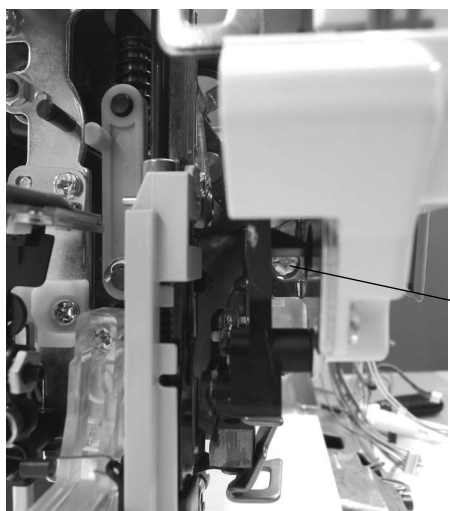
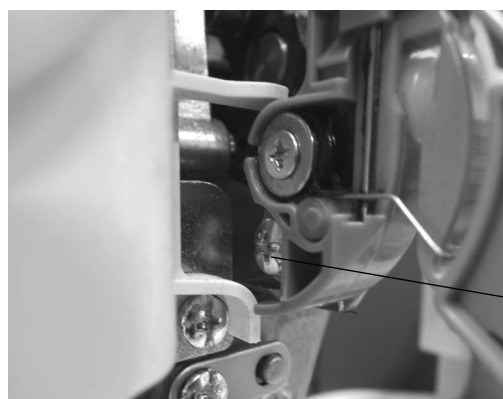
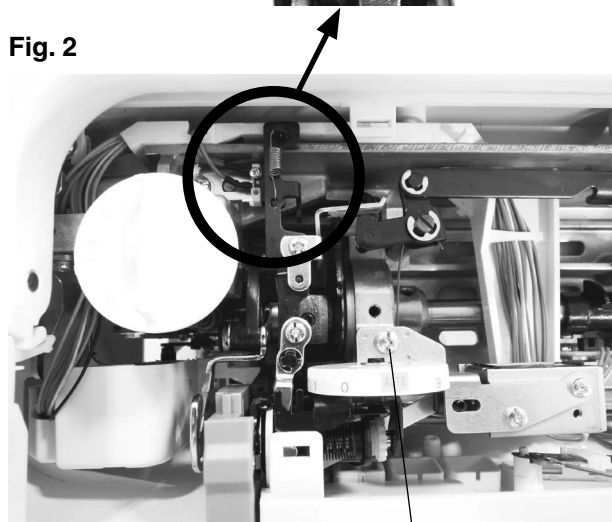

Fig. 2



Thread tension unit

To remove:

1. Remove the top cover and the front cover (see pages 1 and 5).
2. Disconnect the solenoid 1 thread tension release connector from the printed circuit board A (see page 7).
3. Remove the spring on the thread tension release lever (see fig. 1).
4. Remove the setscrews A.
Insert the screwdriver from the left side of the machine.
Remove the setscrews B.
Remove the thread tension unit.

To attach:

1. Follow the above procedure in reverse.
2. Check the upper thread tension (see page 22).

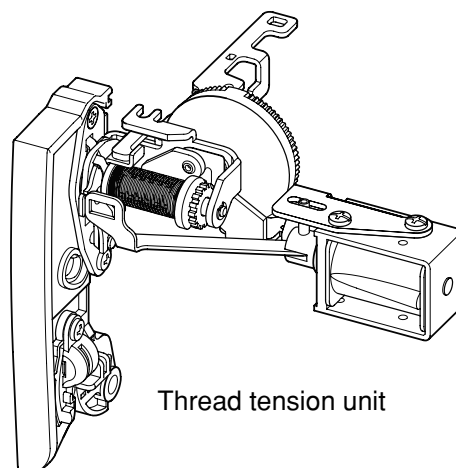

Mechanical adjustment

Feed dog height

When the foot pressure dial is at "7" and the presser foot A is lowered, the highest position of the feed dog should be 0.80 to 0.90 mm from the surface of the needle plate.

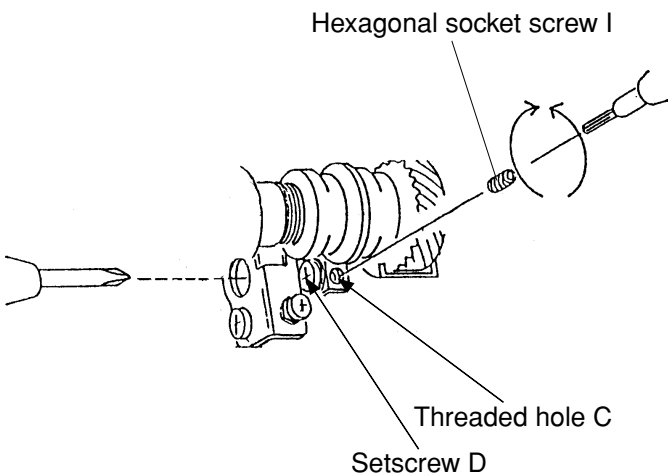
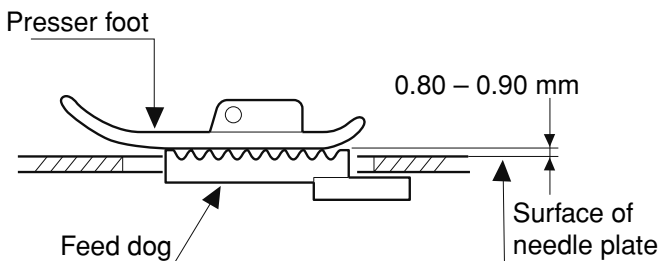
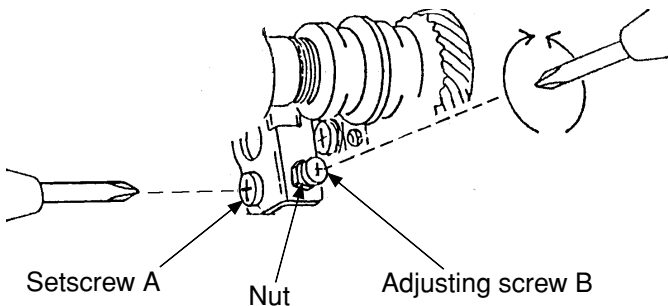
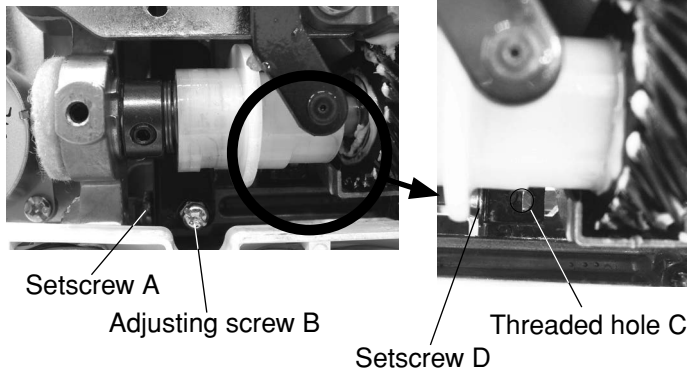

Adjustment 1:

1. Turn the power switch on. Adjust the stitch length at maximum length.
Turn the power switch off.
2. Remove the bed cover and base cover (see page 3).
3. Set the pressure adjusting dial at "7" with the presser foot lowered.
4. Turn the handwheel toward you to raise the feed dog at its highest position.
5. Loosen the setscrew A.
6. Loosen the nut.
Adjust the feed dog height to 0.85 mm by turning the adjusting screw B.
7. Tighten the nut and setscrew A.
8. Attach the bed cover and base cover.

Adjustment 2:

If the feed dog is not parallel to the surface of the needle plate at its highest position, make the adjustment as follows:

* For this adjustment, a hexagonal socket screw I 4x6, part no. 000111108 is required.

1. Insert a hexagonal socket screw I, part no. 000111108 into the threaded hole (C) until it stops.
2. Turn the setscrew D clockwise to loosen it.
3. Turn the hexagonal socket screw I until the feed dog is parallel with the surface of the needle plate.
4. Tighten the setscrew D.
5. Remove the hexagonal socket screw I.
6. Attach the bed cover and base cover.

Mechanical adjustment

Needle drop position

When the straight stitch is selected, the needle should be positioned in the center of the needle plate hole.

When the needle drop position is set at "0.0" and "9.0", the clearance between the side of the needle and the needle hole should be 0.2 mm or more.

Fig. 1

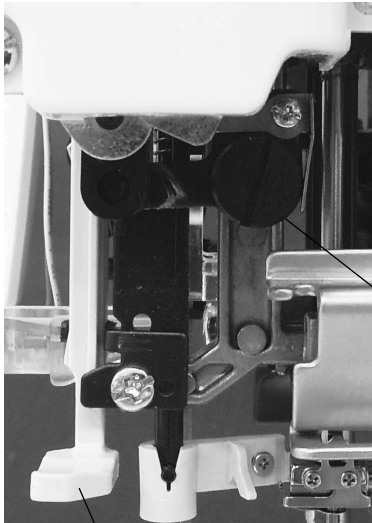
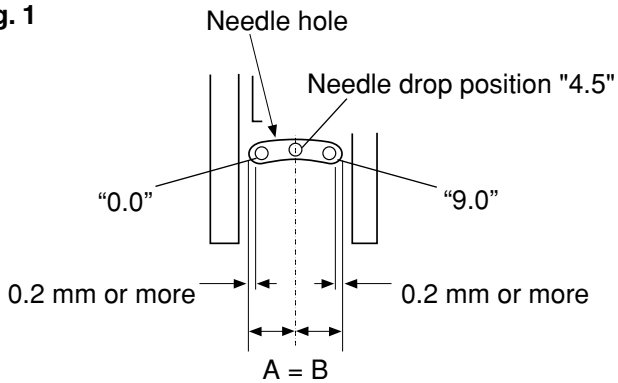

Needle threader

Eccentric pin

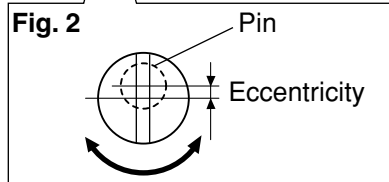

Fig. 2

Pin

Eccentricity

To adjust:

1. Attach the needle #14.
2. Turn the power switch ON. Select straight stitch. Check that the needle drop position is centered when the drop position is set at "4.5", and the clearance between the side of the needle and the needle hole is 0.2 mm or more when the needle drop position is set at "0.0" and "9.0" (see fig. 1). If this is not the case, adjust as follows;
3. Lower the needle threader until the hexagonal socket screw shows up (see fig. 3). Loosen the hexagonal socket screw. Turn the eccentric pin to adjust the needle drop position. The direction of eccentric pin should be as shown as fig. 2.
4. Tighten the hexagonal socket screw. Check the hook timing and the needle bar height after this adjustment (see page 17 and 18).

Fig. 3

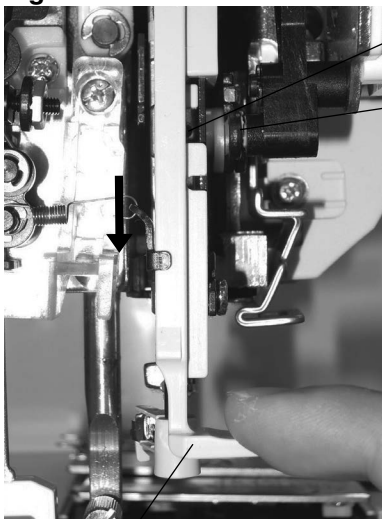

Hexagonal socket screw

Eccentric pin

Needle threader

Mechanical adjustment

Presser bar height

The clearance between the presser foot and the surface of the needle plate should be 6 mm when the presser foot is raised.

The presser foot (zigzag foot A) should be parallel to the slot of the feed dog teeth when attached.

To adjust:

1. Attach the zigzag foot (A).
2. Drop the feed dogs.
3. Raise the presser foot with the presser foot lifter.
4. Open the face cover.
Loosen the setscrew on the presser bar supporter to adjust the presser foot direction as illustrated so the slot for the feed dog teeth and the zigzag foot should be parallel.
5. Place the 6 mm spacer (block) between the presser foot and the needle plate. Tighten the setscrew while depressing the foot against the spacer.

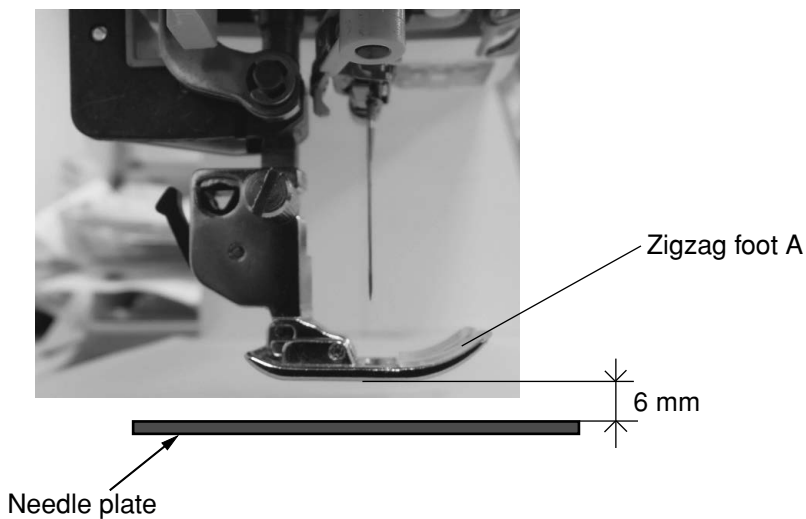
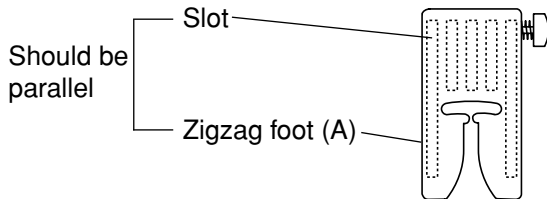
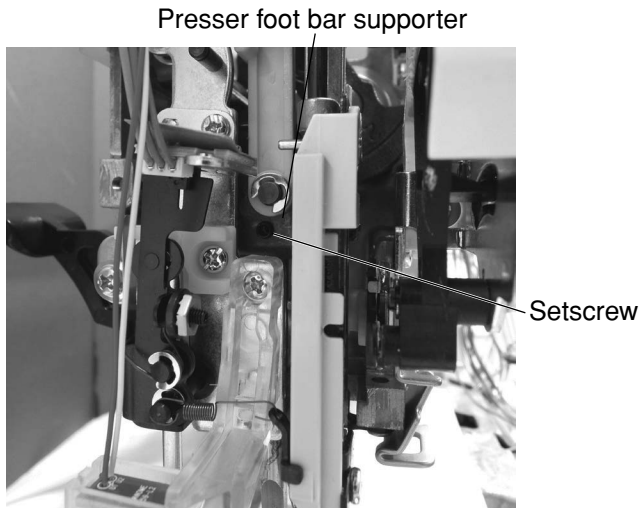

Mechanical adjustment

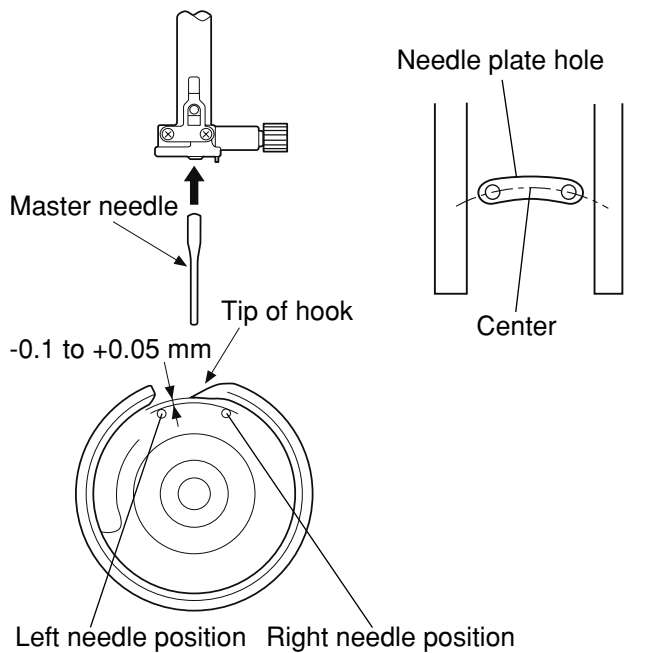

Presser foot pressure adjusting dial

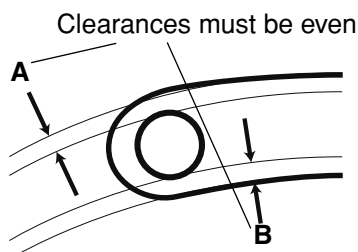
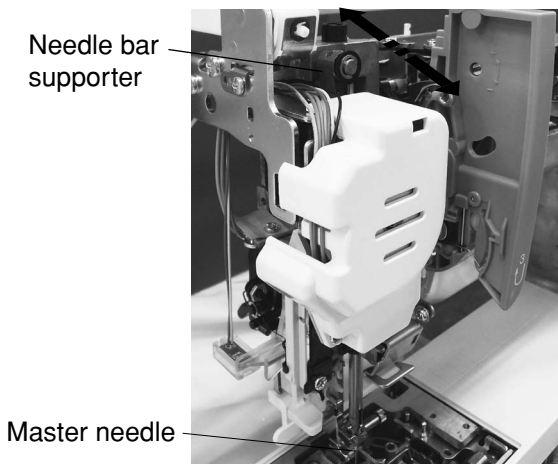

Needle drop position

Adjustment 1

1. Remove the top cover (see page 2).
2. Remove the presser foot pressure dial, presser foot, the needle plate and the bobbin holder.
* Cover the needle plate with the fabric to prevent damaging when removing the needle plate.
3. Attach the master needle.
4. Turn the power switch ON.
Select the zigzag stitch pattern 9.
Adjust the stitch width at its maximum (9.0).
5. Turn the handwheel toward you. Adjust the clearance between the needle and the tip of the rotary hook, by moving the needle bar supporter in the direction of arrow.
Loosen the setscrew and adjust the position of the needle bar.
Tighten the setscrew.
6. Check the clearances A and B between the needle and the edge of needle plate hole. If the clearances are not even, follow the procedure on the next page.

Mechanical adjustment

Clearance between needle and tip of the rotary hook

The clearance between the needle and the point of hook should be -0.1 to $+0.05$ mm.

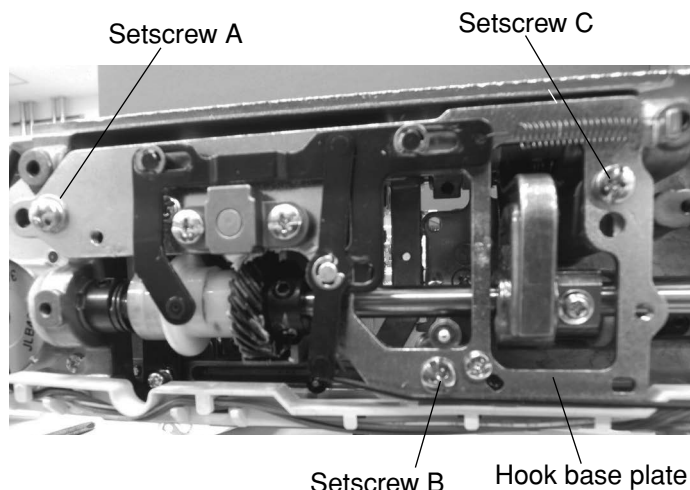

Adjustment 2

1. Remove the bed cover and base cover (see page 3).
2. Turn the power switch ON, and select the zigzag stitch pattern 11.
Adjust the stitch width at its maximum (9.0).
3. Remove the presser foot, needle plate and bobbin holder.
4. Loosen the setscrews A and B.
Loosen the setscrew C just enough to move the hook base plate.
5. Turn the handwheel toward you.
Adjust the clearance between the needle and the tip of the rotary hook by moving the hook base plate up or down between -0.1 and $+0.05$ mm at the both left and right needle position.
6. Tighten the setscrews A, B and C.
7. Check the backlash between the lower shaft gear and the hook drive gear. If the backlash is too great or the engagement of the gears is too tight, adjust the backlash (see page 20).
* Check the hook timing and needle bar height after this adjustment (see pages 17 and 18)
8. Attach the bed cover and base cover.

Mechanical adjustment

Hook timing

The amount of ascending travel of the needle bar from its lowest position to the position (Needle drop position 0.0) where the tip of the rotary hook exactly meets the right side of the needle should be 3.70 to 4.00 mm

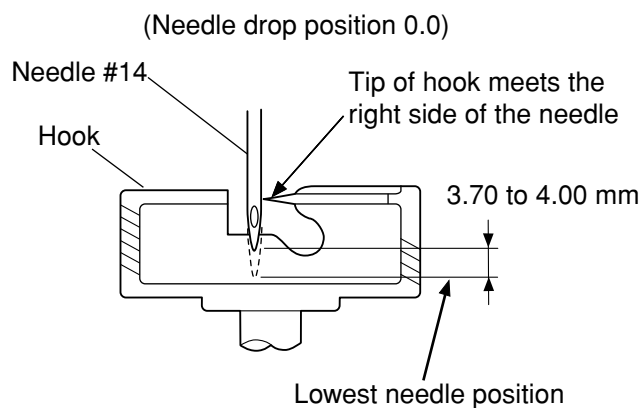

Bobbin holder Hook Tip of hook

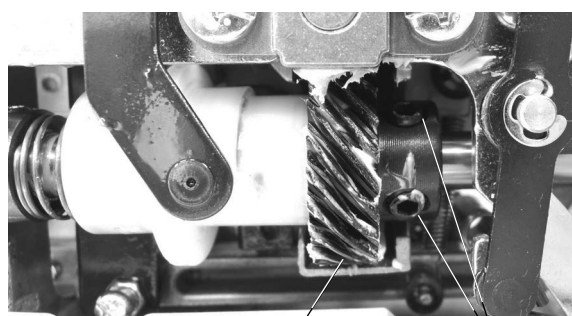

Lower shaft gear Setscrews A

To adjust:

1. Remove the bed cover and base cover (see page 3).
2. Attach the needle #14.
3. Turn the power switch ON. Select straight stitch. Set the needle drop position at "0.0".
* Do not turn the switch OFF.
4. Remove the presser foot, the needle plate and the bobbin holder. (see page 4)
* Cover the needle plate with a fabric to prevent damaging when removing the needle plate.
5. Turn the handwheel toward you to lower the needle at its lowest position.
6. Loosen the setscrews A.
7. Turn the handwheel toward you to raise the needle bar further 3.70 to 4.00 mm from its lowest position.
8. Turn the lower shaft gear until the tip of rotary hook meets with the right side of the needle.
Tighten the setscrews A.
* Check the needle bar height after this adjustment.
9. Attach the bed cover and base cover.

Mechanical adjustment

Needle bar height

The distance between the upper edge of the needle eye and the hook race should be in the range of 1.6 to 2.0 mm when the tip of the hook meets right side of the needle in the needle drop position "0.0" as the needle ascends from its lowest position.

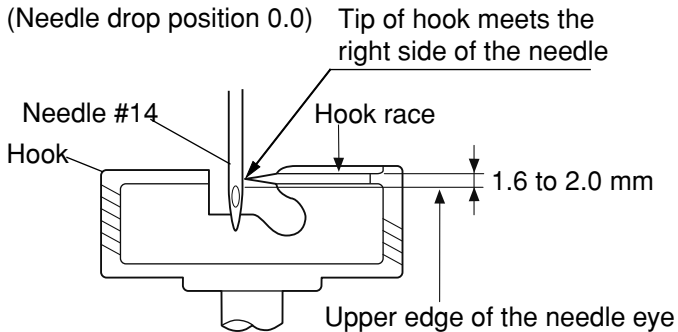

1. Attach the needle #14.
2. Turn the power switch ON. Select straight stitch. Set the needle drop position at "0.0".
* Do not turn the switch OFF.
3. Remove the presser foot, the needle plate and the bobbin holder. (see page 4)
* Cover the needle plate with the fabric to prevent damaging when removing, the needle plate.
4. Turn the handwheel toward you until the tip of hook meets the right side of the needle.
5. Loosen the hexagonal socket screw.
6. Move the needle bar to adjust the needle bar height. Tighten the hexagonal socket screw. Be careful not to turn the needle bar.
7. Attach the bobbin holder and the needle plate.

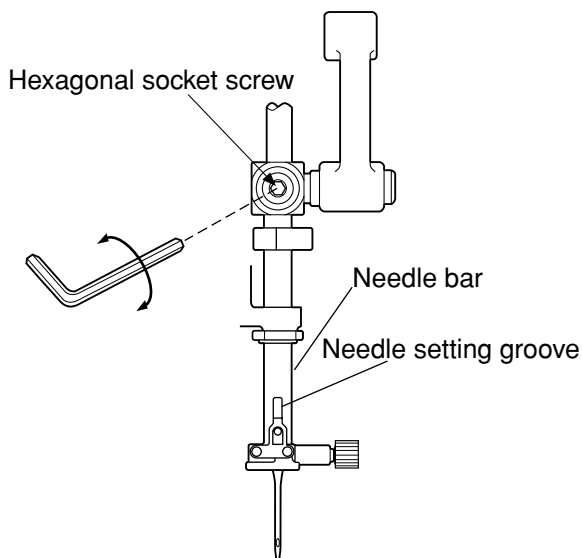
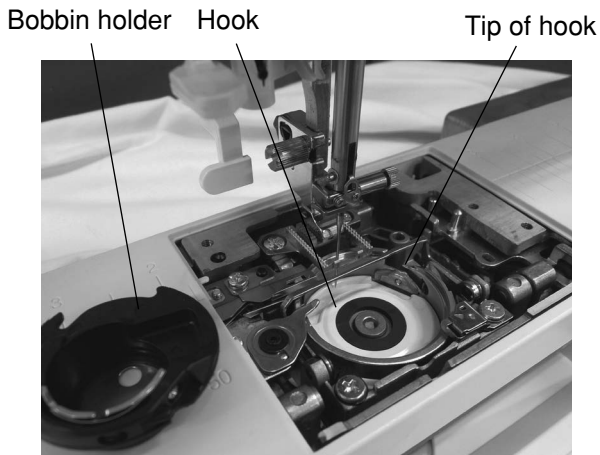

Mechanical adjustment

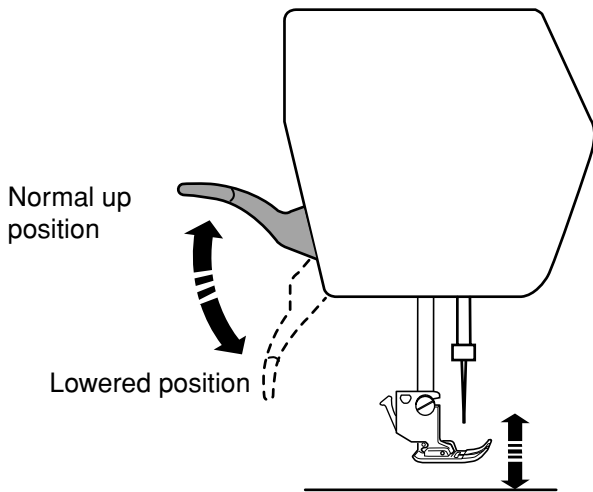
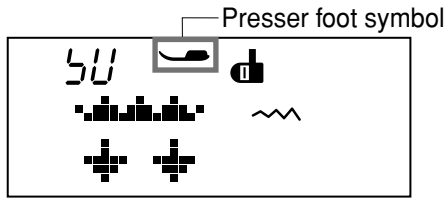

Setscrew A
Switch set plate

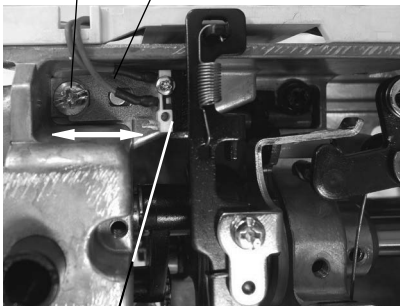

Presser bar lifter switch

Top left side of the machine
(Presser foot presser dial removed)

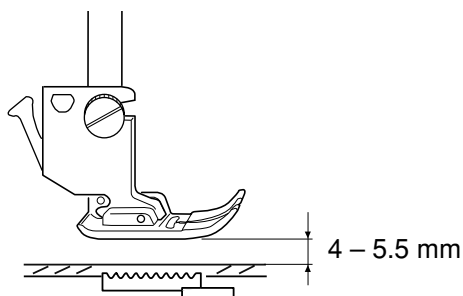

Presser bar lifter switch position adjustment

To check:

1. While pressing the needle up/down and lock stitch buttons, turn the power switch on. The LCD displays "----".
2. Press "5" key to enter the sensor test mode.
3. When the presser bar is at normal up position, the presser foot symbol appears. When the presser bar is at lowered position, the presser foot symbol disappears. If not, follow the procedure below.

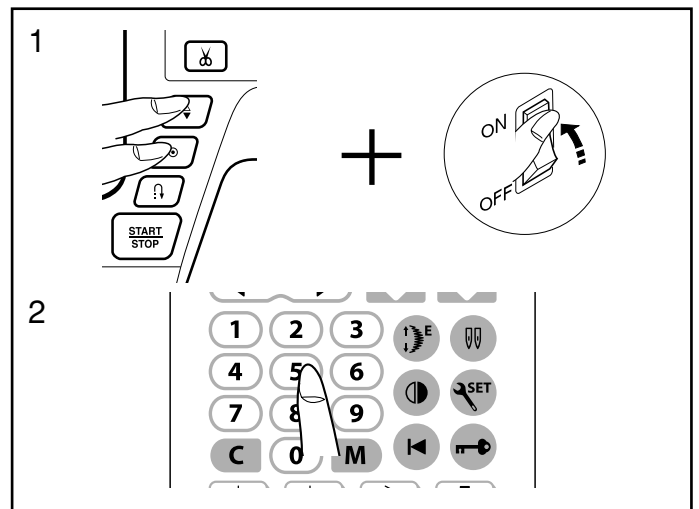

To adjust:

1. Remove the top cover (see page 2).
2. Loosen the setscrew A and adjust the position of the switch set plate. The clearance between the foot and needle plate should be in the range of 4 to 5.5 mm when the presser foot symbol disappears.
3. Turn off the power switch.
4. Attach the top cover.

Mechanical adjustment

Backlash between hook drive gear and lower shaft gear

The rotary play of the hook should be 0.8 mm or less when the tip of rotary hook is within the width of feed dog.

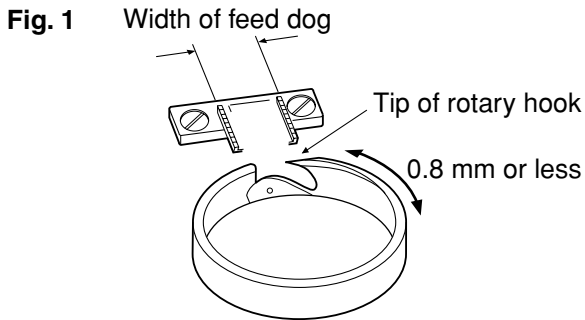

1. Remove the base cover and bed cover (see page 3).
2. Remove the presser foot, the needle plate and the bobbin holder.
* Cover the needle plate with the fabric to prevent damaging when removing, the needle plate.
3. Turn the handwheel toward you so the tip of the rotary hook is within the width of feed dog as shown in Fig 1.
Check the rotary play of the hook.
4. If the backlash is too much or too little, loosen the hexagonal socket screw (C) and (D) and following the adjustment procedure.
If the backlash is too great (more than 0.8 mm), turn the both lower shaft bushings in direction A. If the engagement of gear is too tight, and the machine does not turn smoothly, turn the both lower shaft bushings in direction B.
Adjust the grooves of the lower shaft bushing as well.
5. Tighten the hexagonal socket screws (C) and (D).
6. Attach the base cover, bed cover, the presser foot, needle plate and the bobbin holder.

Lower bushing of the front side

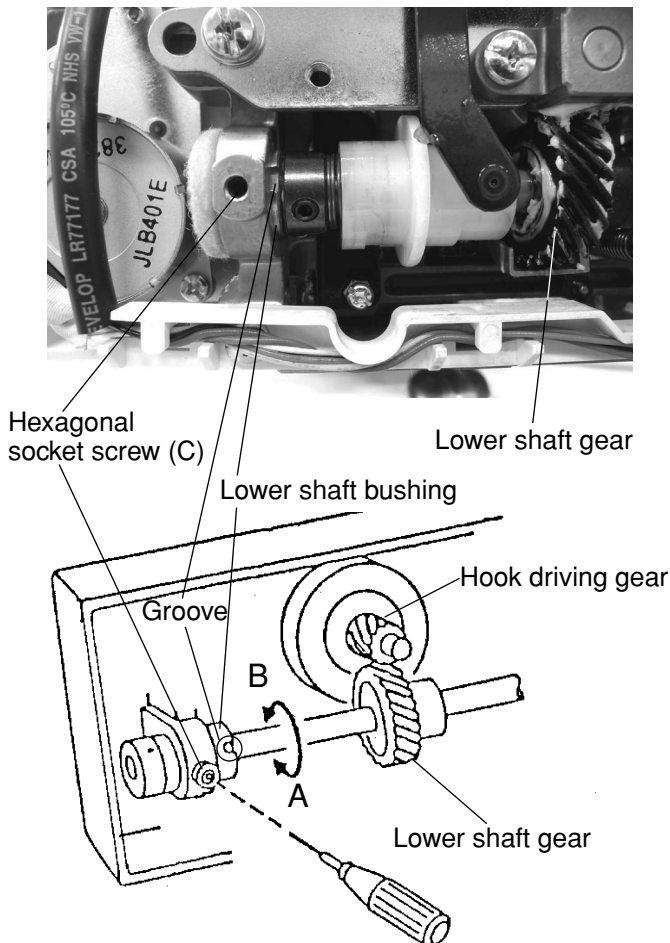

Lower bushing of the belt cover

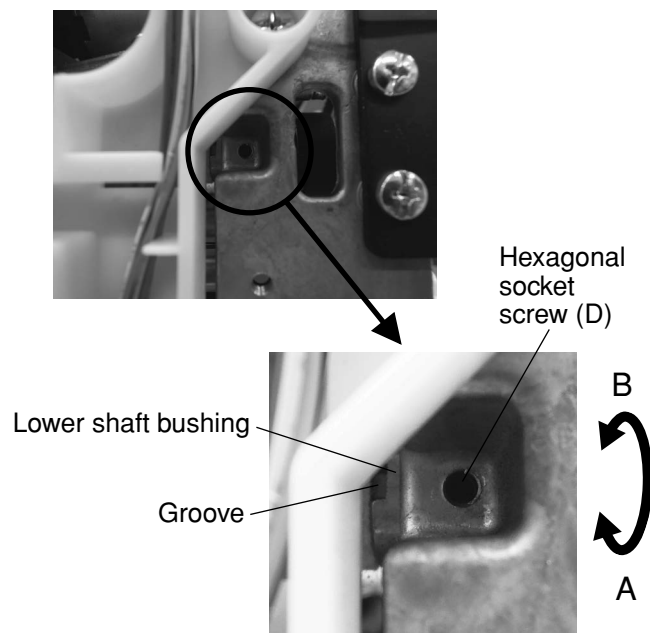

Mechanical adjustment

Upper shaft shield plate position

When the machine is set for zigzag stitch, the needle should start to swing 7.2 to 8.2 mm above the surface of the needle plate.

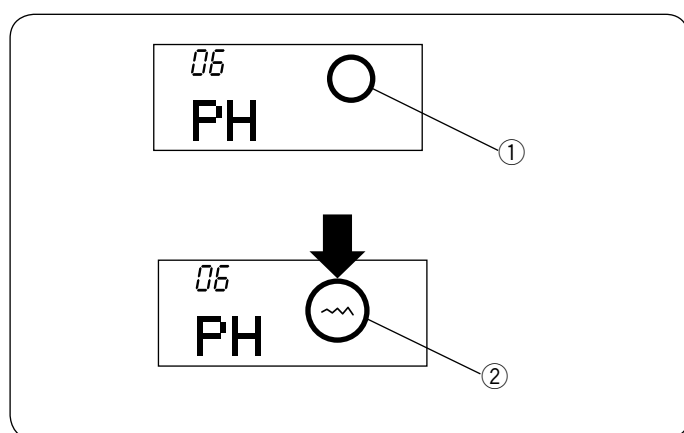
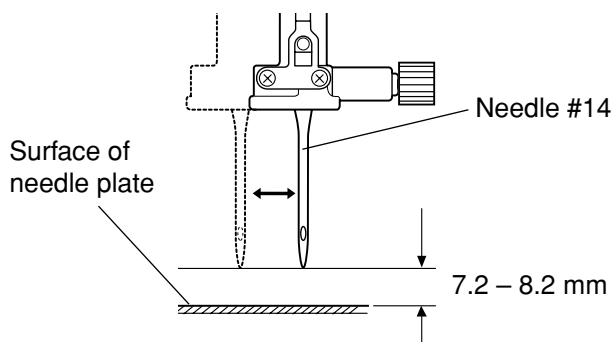

To check:

1. Attach the needle #14.
2. While pressing the needle up/down and lock stitch buttons, turn the power switch on. The LCD display "----".
3. Press "1" key to enter the self-diagnostic mode. Press the start/stop button 5 times to enter phase check mode (LCD displays "06" and "PH").
4. Turn the handwheel toward you until PH changes to " " ① to "~~~~" ② on LCD.
5. The needle height should be 7.2 to 8.2 mm above from the surface of the needle plate. If not, adjust the upper shaft shield position.

To adjust:

1. Remove the top cover.
2. While pressing the needle up/down and lock stitch buttons, turn the power switch on. The LCD display "----". Press "1" key to enter the self-diagnostic mode. Press the start/stop button 5 times to enter phase check mode (LCD displays "06" and "PH").
3. Turn the handwheel toward you to raise the needle at 7.7 mm above the surface of the needle.
4. Loosen the setscrew A of the lower shaft shield plate. Turn shield plate until the sensor signal changes from " " ① to "~~~~" ②.
5. Position the lower shaft shield plate in the center of slit of the lower shaft sensor (see fig. 1). Tighten the setscrew A.
5. Attach the top cover.

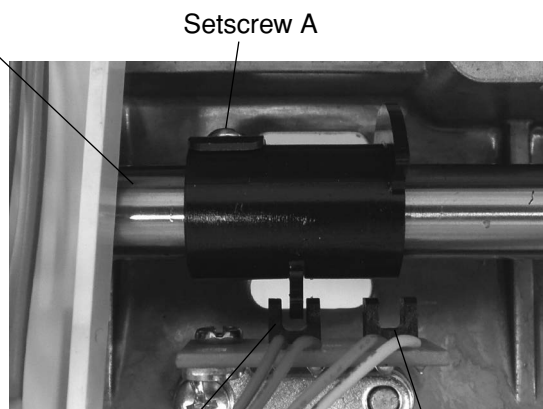
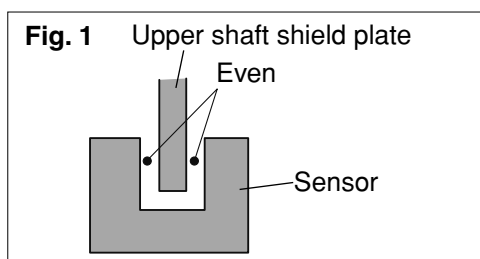
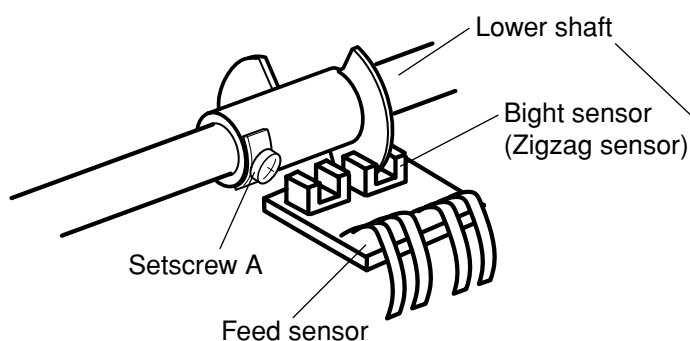

Feed sensor Bight sensor (Zigzag sensor)

Mechanical adjustment

Upper thread tension

The standard upper thread tension should be 75 to 90 grams when pulling the thread (while polyester thread size 50) at the speed of 110 mm/sec with the tension at "AUTO" (Be sure the presser foot is lowered).

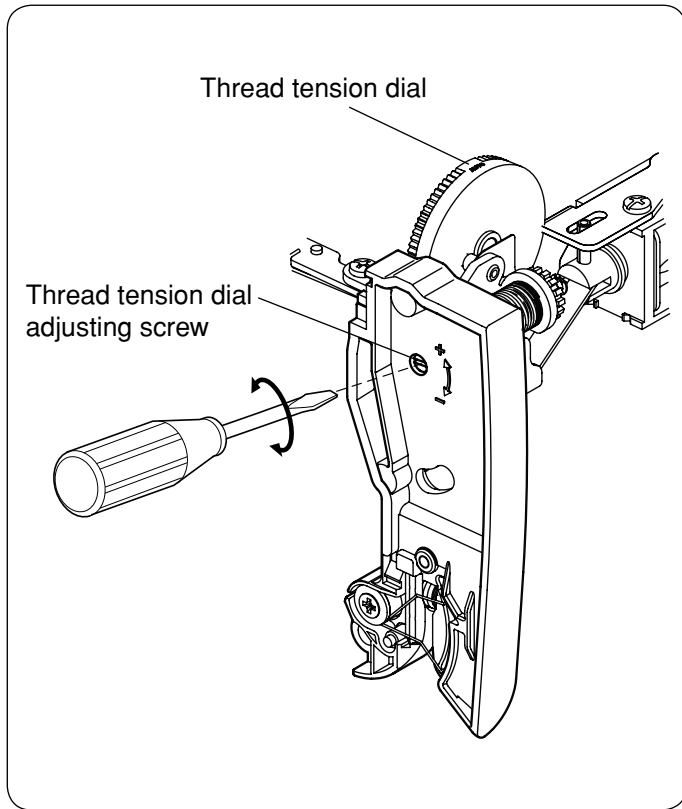

- 1 Set the thread tension dial to "AUTO".
- 2 Open the face cover.
Adjust the tension by turning the thread tension adjusting screw.

To lower the tension, turn it clockwise (in the direction of "-").

To tighten the tension, turn it counterclockwise (in the direction of "+").

Pulling direction: (pulling speed 110 mm/sec.)

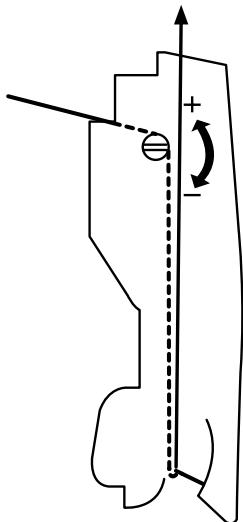

Mechanical adjustment

Needle threader plate

If the hook of the threader plate is damaged, change or adjust the part as follows:

Fig. 1

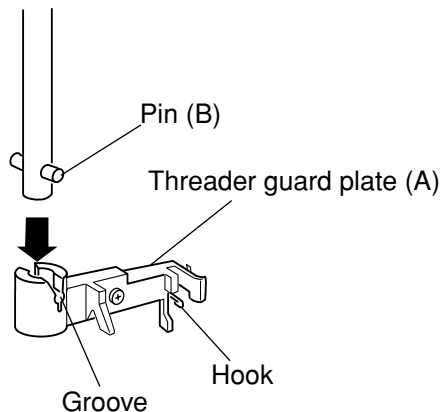

To remove:

- 1 Push down the needle threader knob and pull the needle threader guard plate (A) down to remove it (see fig. 1).
- 2 To install the needle threader plate, line the groove up with the pin (B) and push it up to snap it.

To adjust:

- 3 If the hook on the threader plate touches the left or right side of the needle eye, loosen setscrew (C) and adjust the hook position (fig. 2).
- 4 If the hook on the threader plate touches the top or bottom side of the needle eye, loosen setscrew (D) and adjust the hook position (fig. 3).

Fig. 2

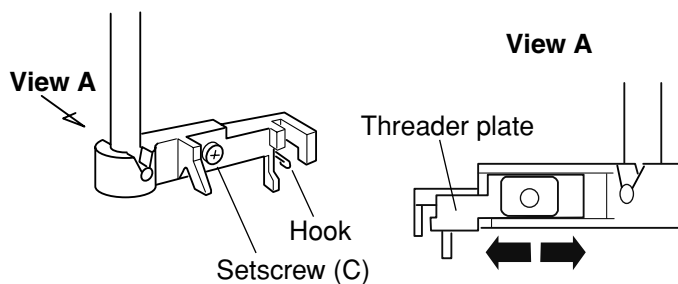
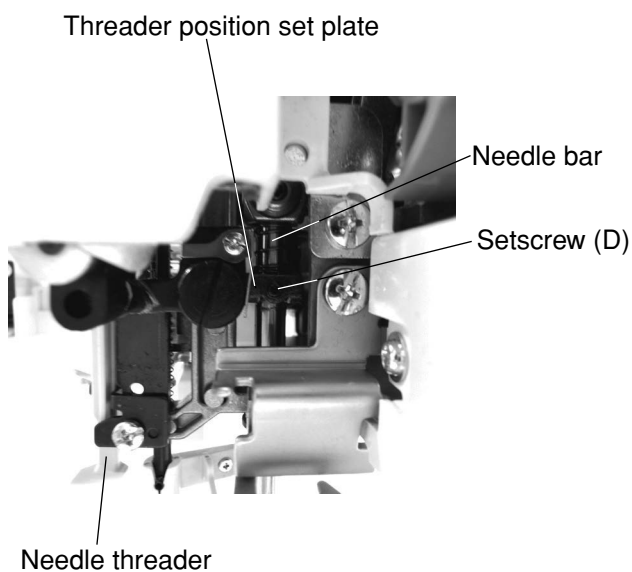
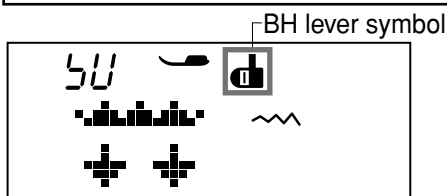
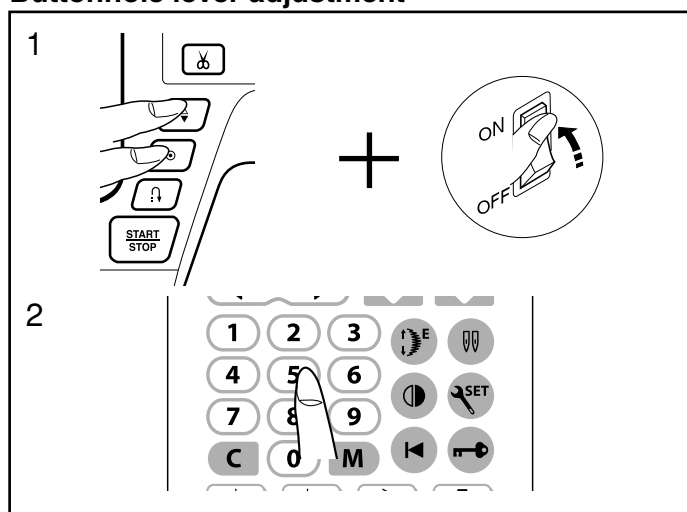

Fig. 3



Mechanical adjustment

Buttonhole lever adjustment



To prepare:

1. While pressing the needle up/down and lock stitch buttons, turn the power switch on.
The LCD display "----".
Press "5" key to enter the sensor test mode.
2. Attach the automatic buttonhole foot R.
Place a piece of paper between the presser foot and the needle plate for easier adjustment.

Buttonhole lever sensor position adjustment:

1. Adjust the clearance between the stopper and the presser foot slider to 1.6 mm.
Lower the buttonhole foot and the buttonhole lever.
2. Loosen the hexagonal socket screw until LCD displays BH lever symbol. Tighten the hexagonal socket screw slowly until the lever symbol disappears.

Buttonhole lever guide adjustment:

1. Adjust the clearance between the stopper and the presser foot slider to 2.6 mm.
Lower the buttonhole foot.
2. Lower the buttonhole lever. Loosen the setscrew of the Buttonhole lever guide.
Adjust the buttonhole lever guide left or right so the Buttonhole lever slightly touches to the Buttonhole foot.
Tighten the setscrew.

To check:

1. While pressing the needle up/down and lock stitch buttons, turn the power switch on.
The LCD display "----".
Press "5" key to enter the sensor test mode.
2. Adjust the clearance between the stopper and the presser foot slider to 1.4 mm.
Be sure that the LCD displays BH lever symbol.
Adjust the clearance between the stopper and the presser foot slider to 1.8 mm.
Be sure that the BH lever symbol disappears.
If the BH lever symbol appears, adjust the buttonhole sensor position again.
3. After checking the buttonhole sensor position, Slide the buttonhole lever so the buttonhole lever does not touch to the buttonhole foot (Buttonhole lever should be released).
Be sure that BH lever symbol is not on the LCD.
Move the buttonhole lever to the right and left very slightly, and be sure again that the BH lever symbol is not shown on the LCD.
If the BH lever symbol appears, adjust the buttonhole lever guide adjustment again.

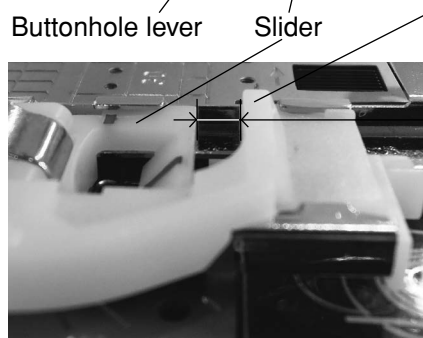
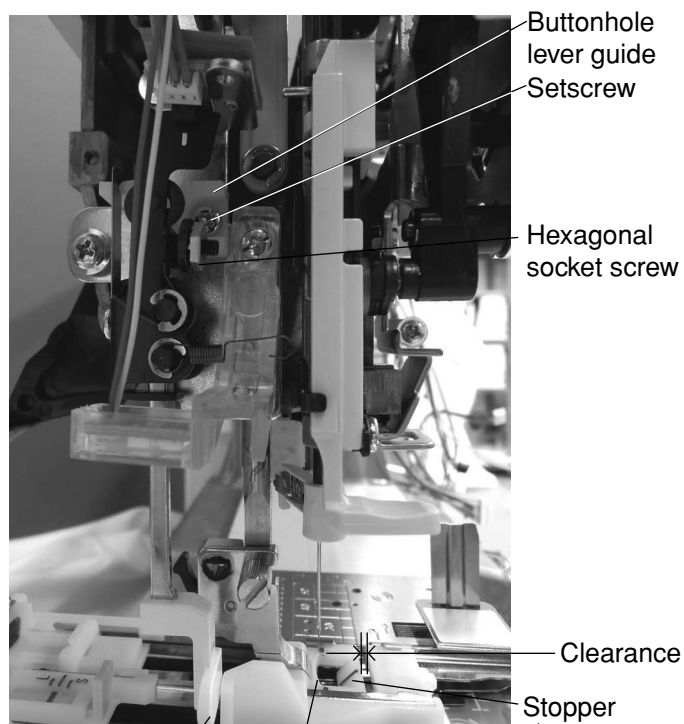

Mechanical adjustment

Thread cutter

The distance between the end of thread cutter plate slit and the edge of moving cutter should be in the range of 0.4 to 1.2 mm.

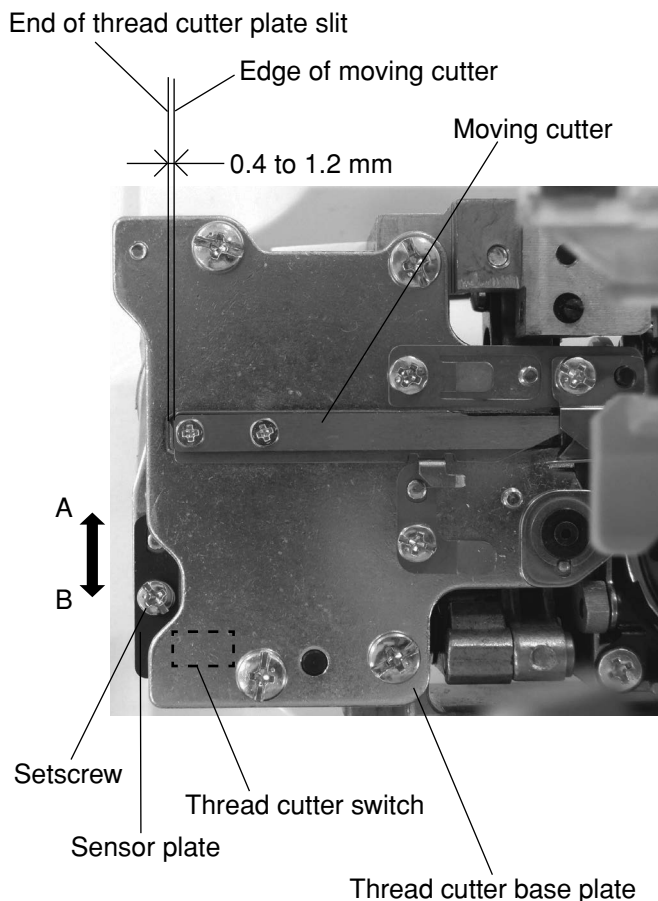
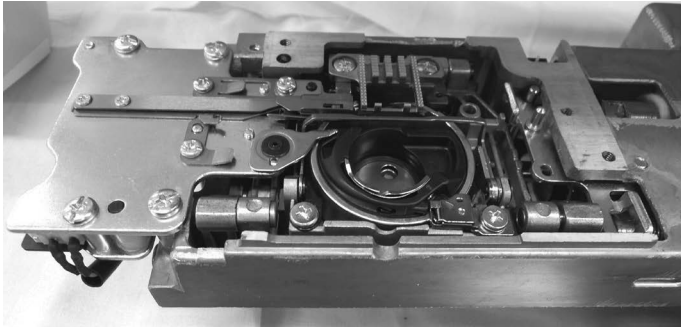

To check:

1. Remove the bed cover and free arm cover (see page 3, 4).
2. Turn the power switch off. Slide the moving cutter to the right with your finger.
3. Turn the power switch on. The moving cutter motor is initialized, and moving cutter moves to its home position automatically.
4. The distance between the edge of moving cutter and the end of thread cutter plate slit should be 0.4 to 1.2 mm. If not, follow the procedure below.

To adjust:

1. Loosen the setscrew on the sensor plate.
2. Adjust the distance between the end of thread cutter plate slit and the edge of moving cutter to 0.8 mm by moving the sensor plate in the direction of A or B.
3. Attach the bed cover and free arm cover.

Mechanical adjustment

Solenoid position adjustment

When the tension disk is closed, the clearance between the plunger and the end of yoke should be 2.0 mm.

TOP VIEW

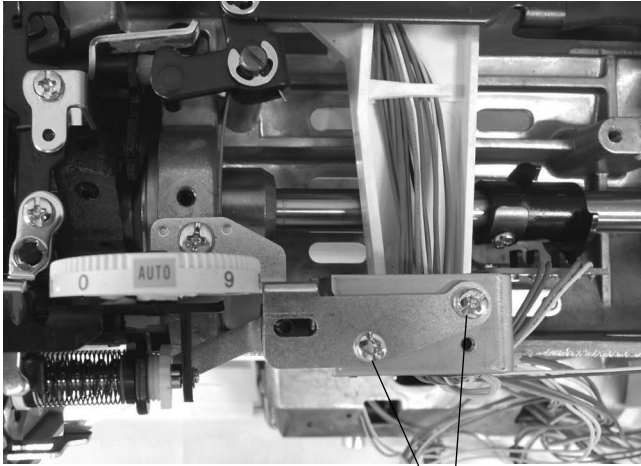

Side view

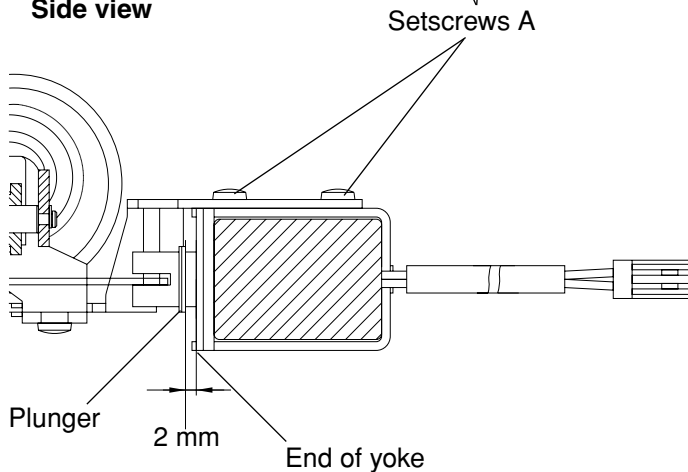

[To check]

1. Remove the top cover (see page 2).
2. While pressing the needle up/down and lock stitch buttons, turn the power switch on.
The LCD display "----".
Press "4" key to enter the solenoid test mode.
3. Press the needle up/down button to release the thread tension.
The LCD will display "--on".
Make sure the needle thread in the tension disk can be pulled when the confirm button is pressed.
4. Turn the power switch off.
5. Attach the top cover.

[Adjustment]

1. Remove the top cover.
2. Loosen the setscrews A.
3. Adjust the clearance between the plunger and the yoke to 2 mm with the tension disk closed.
4. Tighten the setscrews A.
5. Attach the top cover.

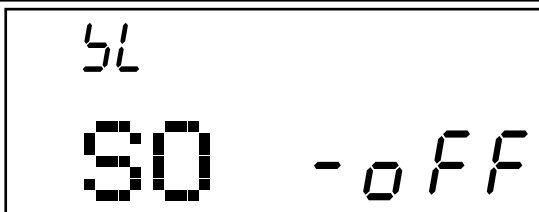
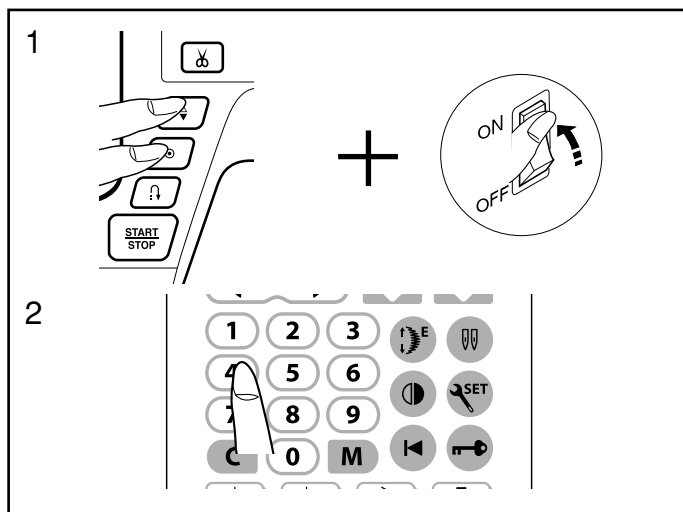

Mechanical adjustment

Stretch stitch feed balance

Adjust the stretch stitch balance dial at the setting mark.

The measurement of five of test patterns should be in the range of 33 to 39 mm as shown.

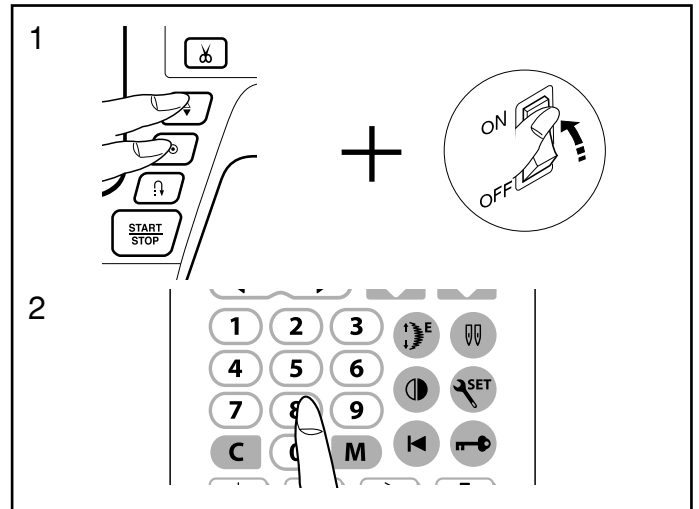
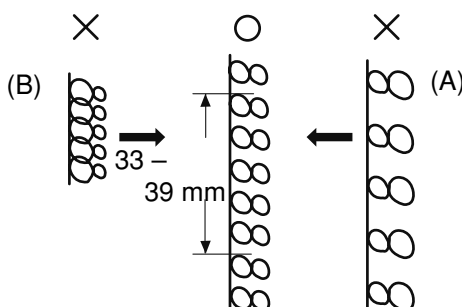
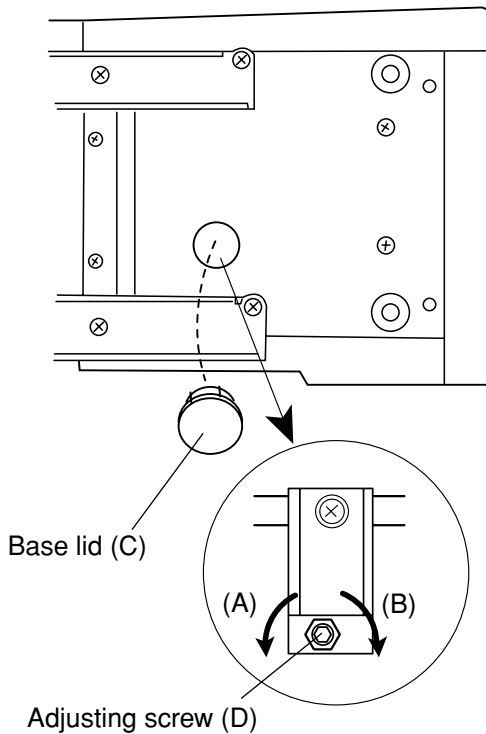
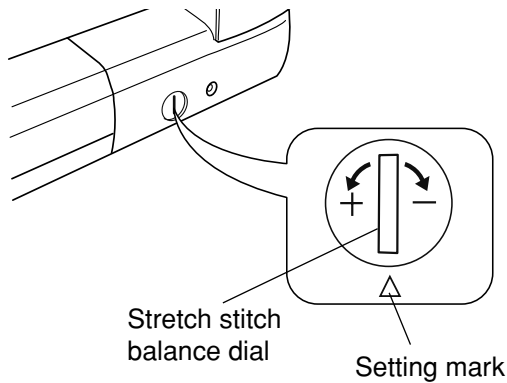
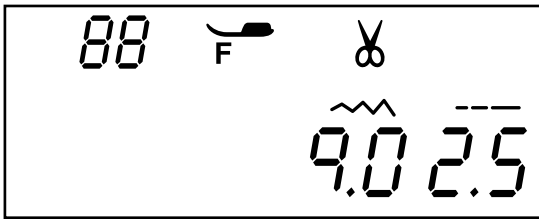

To adjust:

1. While pressing the needle up/down and lock stitch buttons, turn the power switch on. The LCD display "----". Press "8" key.
2. Set the stretch stitch balance dial at the setting mark.
3. Attach the satin stitch foot (F). Sew test patterns and check the measurement of five of them. The range of patterns should be in the range of 33 to 39.
4. If not, remove the base lid C. Press the right arrow of button. The adjusting screw D comes to the adjusting position.
 - Turn the adjusting screw in the direction of A if the measurement is more than 39 mm.
 - Turn the adjusting screw in the direction of B if the measurement is less than 33 mm.
5. Press the right arrow of button and sew test patterns. Check the measurement of five of them.
6. Turn off the power switch.
7. Attach the base lid C.

Mechanical adjustment

Needle plate switch

Fig. 1

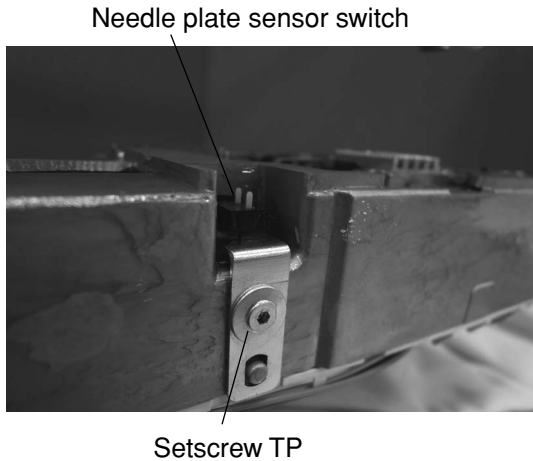

To check and adjustment:

1. Prepare the needle plate and the needle plate for straight stitch.
2. Remove the bed cover and free arm cover.
3. Insert the needle plate base plate under the fixed cutter spacer and the slide plate positioning plate. Press the  mark to attach the needle plate.
4. The distance between the bottom side of the needle plate and the micro switch base plate should be in the range of 11 – 11.5 mm.
If not, loosen the setscrew TP and move the base plate up or down to adjust it. Tighten the setscrew TP firmly after the adjustment.
The actuator of the micro switch should be aligned with the needle plate sensor knob as shown in fig 3.

(Needle plate sensor switch)

To remove:

1. Remove the base cover, bed cover and the free-arm cover (see page 2 to 4).
2. Disconnect the needle plate sensor switch connector from the printed circuit board A (see page 7).
3. Remove the setscrew TP and the needle plate sensor switch.

To attach:

1. Attach the needle plate sensor switch with the setscrew TP. Tighten the setscrew TP lightly.
2. Connect the needle plate sensor switch connector to the printed circuit board A.
3. Check the needle plate sensor and adjust as necessary (see the adjustment procedure above).
4. Tighten the setscrew TP firmly.
5. Attach the base cover, bed cover and free-arm cover.

Fig. 2

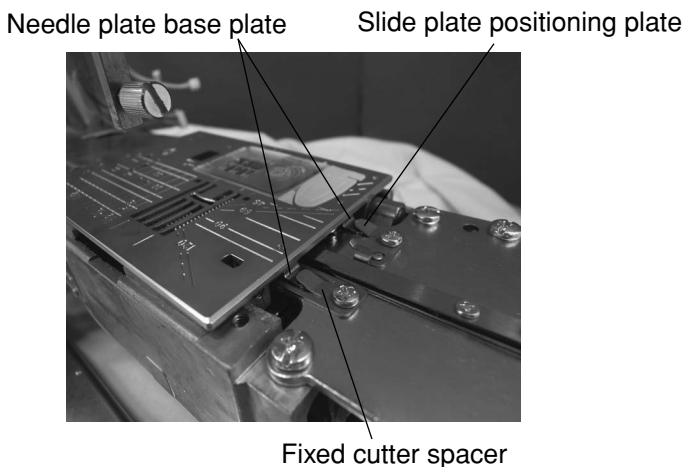
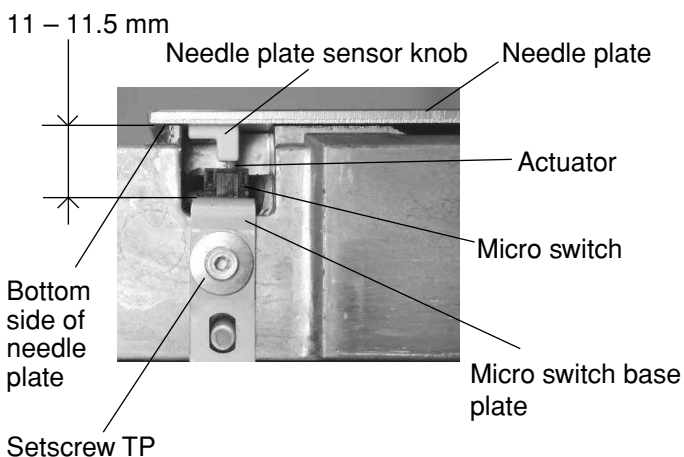
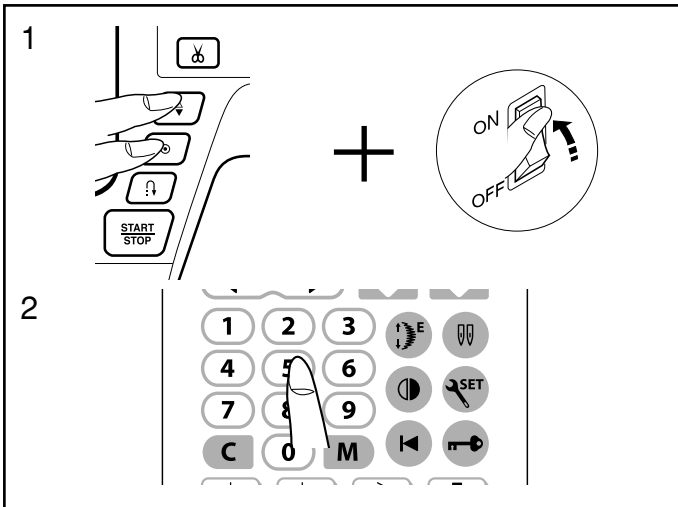

Fig. 3



Mechanical adjustment



To check:

1. While pressing the needle up/down and lock stitch buttons, turn the power switch on. The LCD display "----". Press "5" key to enter the sensor test mode.

Needle plate attached:

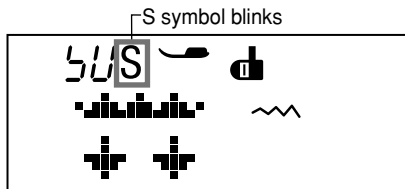

Needle plate for straight stitch attached:

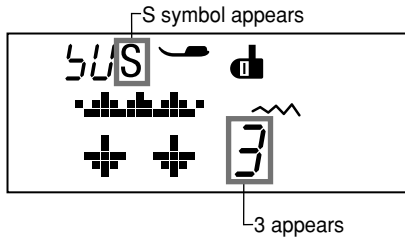

2. Be sure that S symbol appears and blinks when the needle plate is attached.

3. Replace the needle plate with the needle plate for straight stitch. Be sure that S symbol and number 3 appears. If not, adjust the micro switch base plate position (see page 28).

* To remove the needle plate, press the needle plate replacing bar in the direction of arrow with a screwdriver.

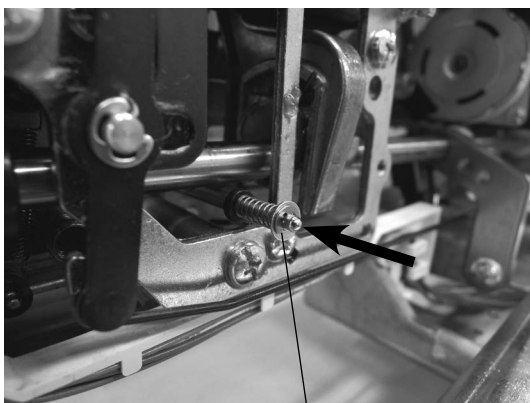

Needle plate replacing bar

Diagnosis test

NOTE:

1. Be sure to disconnect the machine from the power supply when replacing parts.
2. The language on the LCD is English only.

Preparation

1. Shift the bobbin winder spindle to the right.
2. Turn the drop feed lever to the right (away from you) to raise the feed dog.
3. Slide the speed adjusting lever to the left.
4. Remove the presser foot and raise the presser bar lifter (at normal up position).
5. Set the needle bar at its highest position.

Before starting the diagnosis test.

Check or replace the following part(s) if nothing happens when the power switch is turned on:

1. Be sure that the machine is plugged in.
2. Be sure that the connectors are connected to the printed circuit board A (refer to page 7).
3. Replace the printed circuit board A (refer to page 7)
4. Replace the power supply cord.
5. Replace the switching power supply.



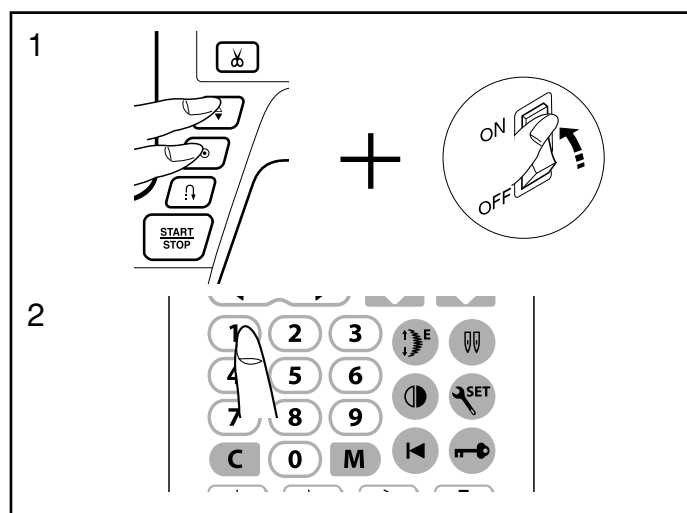

When replacing the sewing lamps or the printed circuit boards, do not turn on the machine.







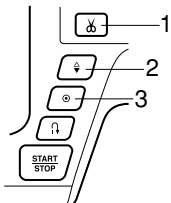

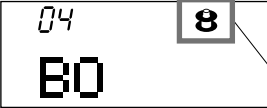
To start the diagnosis test:

1. While pressing the needle up/down and lock stitch buttons, turn the power switch on.
The LCD screens display "----".
2. Press "1" key to enter the self-diagnostic mode.

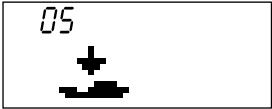

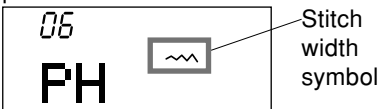
Diagnosis test

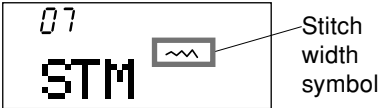
STEP AND ITEMS TO CHECK	PROCEDURE	CORRECT CONDITION	DEFECTIVE CONDITION
01) FUNCTION OF LCD, BUZZER AND LAMP	Turn on the power switch while simultaneously pressing the needle up/down button and thread cutter button. Press "1" key. If the result is correct condition, press the start/stop button to proceed the next step. If the result is defective condition, press the reverse stitch button to proceed the next step.	Sewing lamp and LCD backlight lit. LCD displays "----".  Buzzer sounds. LCD displays symbols and numbers and blinks. Start/stop button blinks in red and green. 	"1" button is not responding. Sewing lamp does not lit. LCD backlight does not lit. LCD does not display. Buzzer does not sound. Machine lamp does not turned on. LCD does not display any symbols or not in order. –REMEDY– Calibrate the key position or replace the touch panel. Replace the circuit board A. Replace the machine lamp. Replace the touch panel. Replace the circuit board F.
02) BUTTON	 Press buttons 1– 3. If the result is correct condition, press the start/stop button to proceed the next step. If the result is defective condition, press the reverse stitch button to proceed the next step.	LCD displays "02" and "KEY". Buzzer sounds when button is pressed. Button number is displayed when the button is pressed.  LCD displays "F1" when button 1 is pressed. LCD displays "F2" when button 2 is pressed. LCD displays "F3" when button 3 is pressed.	Buzzer does not sound. LCD does not display the number correctly. –REMEDY– Replace the circuit board A. Replace the circuit board F.
03) BUTTONHOLE SENSOR	Lower the buttonhole lever. Move the buttonhole lever back and forth. If the result is correct condition, press the start/stop button to proceed the next step. If the result is defective condition, press the reverse stitch button to proceed the next step.	LCD displays "03" and "BH". When the buttonhole lever is pulled, buzzer sounds and LCD displays BH symbol.  When the buttonhole lever is pushed, buzzer sounds and LCD displays BH symbol.	Buzzer does not sound. BH symbol does not appear. –REMEDY– Adjust the BH lever sensor position. Replace the BH lever sensor. Replace the circuit board A.
04) BOBBIN WINDER SWITCH	Move the bobbin winder spindle to the right. Return it to the left. If the result is correct condition, press the start/stop button to proceed the next step. If the result is defective condition, press the reverse stitch button to proceed the next step.	LCD displays "04" and "BO". When the bobbin winder spindle is moved to the right, buzzer sounds and the bobbin symbol appears on LCD. When the bobbin winder spindle is moved to the left, buzzer sounds and the bobbin symbol disappears. 	Buzzer does not sound. Bobbin symbol is not displayed. –REMEDY– Adjust the bobbin winder switch position. Replace the bobbin winder switch. Replace the circuit board A.

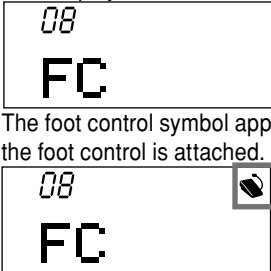
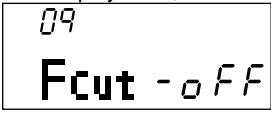
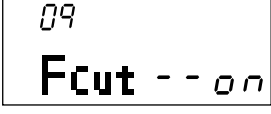
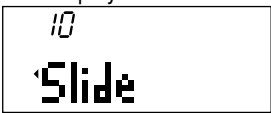

Diagnosis test

STEP AND ITEMS TO CHECK	PROCEDURE	CORRECT CONDITION	DEFECTIVE CONDITION
05) PRESSER FOOT LIFTER SWITCH	<p>Move the presser foot lifter up and down.</p> <p>If the result is correct condition, press the start/stop button to proceed the next step.</p> <p>If the result is defective condition, press the reverse stitch button to proceed the next step.</p>	<p>LCD displays "05" and presser foot symbol.</p> <p>When the presser foot lifter is raised, LCD displays as Fig. 1.</p> <p>Fig. 1 </p> <p>When the presser foot lifer is lowered, buzzer sounds and LCD displays as Fig. 2.</p> <p>Fig. 2 </p>	<p>Buzzer does not sound. Presser foot symbol does not change.</p> <p>–REMEDY– Adjust the presser foot lifter switch position. Replace the presser foot lifter switch. Replace the circuit board A.</p>
06) UPPER SHAFT SHIELD POSITIONING SENSOR	<p>Turn the handwheel toward you. Lower the needle bar from its highest to lowest position. Raise the needle bar from its lowest position to highest position.</p> <p>If the result is correct condition, press the start/stop button to proceed the next step.</p> <p>If the result is defective condition, press the reverse stitch button to proceed the next step.</p>	<p>LCD displays "06" and "PH".</p> <p></p> <p>Turn the handwheel. LCD displays stitch width symbol when the needle bar is at zigzag phase.</p> <p></p> <p>LCD displays stitch length symbol when the needle bar is at feed phase.</p> <p></p>	<p>Buzzer does not sound. Stitch width or length symbol does not appear.</p> <p>–REMEDY– Adjust the upper shaft shield plate position. Replace the sensor. Replace the circuit board A.</p>
07) ZIGZAG MOTOR (STEP MOTOR) AND FEED MOTOR	<p>Turn the handwheel toward you. Lower the needle bar its highest to position (zigzag phase). Press the needle up/down button.</p> <p>Raise the needle bar from its lowest position to its highest position (feed phase). Press the needle up/down button.</p> <p>If the result is correct condition, press the start/stop button to proceed the next step.</p> <p>If the result is defective condition, press the reverse stitch button to proceed the next step.</p>	<p>LCD displays "07" and "STM".</p> <p></p> <p>Press the needle up/down button when LCD displays stitch width symbol. The Zigzag motor will be initialized and get its default position.</p> <p></p> <p>Press the needle up/down button when LCD displays stitch length symbol. The feed motor will be initialized and get its default position.</p>	<p>Zigzag motor does not get default position. Buzzer does not sound. LCD displays "E1".</p> <p>–REMEDY– Adjust the upper shaft shield plate position. Replace the zigzag motor. Replace the circuit board A.</p> <hr/> <p>Feed motor does not get default position. Buzzer does not sound. LCD displays "E2".</p> <p>–REMEDY– Adjust the upper shaft shield plate position. Replace the feed motor. Replace the circuit board A.</p>

Diagnosis test

STEP AND ITEMS TO CHECK	PROCEDURE	CORRECT CONDITION	DEFECTIVE CONDITION
08) FOOT CONTROL	Attach the foot control to the machine. Depress the foot control as far as it goes, then release it. If the result is correct condition, press the start/stop button to proceed the next step. If the result is defective condition, press the reverse stitch button to proceed the next step.	LCD displays "08" and "FC".  The foot control symbol appears when the foot control is attached. Buzzer sounds when the foot control is deeply depressed or released. Buzzer sounds when the foot control is connected or disconnected.	The foot control symbol does not appear. Buzzer does not sound. –REMEDY– Replace the foot control. Replace the machine socket (foot control socket). Replace the circuit board A.
09) FOOT CUT (THREAD CUTTER SWITCH)	Attach the thread cutter switch to the machine. Depress the thread cutter switch as far as it goes, then release it. If the result is correct condition, press the start/stop button to proceed the next step. If the result is defective condition, press the reverse stitch button to proceed the next step.	LCD displays "09", "Fcut" and "-oFF".   Buzzer sounds and "--on" appears when the thread cutter switch is deeply depressed.	Buzzer does not sound. LCD does not display the "Fcut-on". –REMEDY– Replace the thread cutter switch. Replace the machine socket (thread cutter switch socket). Replace the circuit board A.
10) SLIDE VOLUME	Shift the slide volume from left to right, then return to the left. If the result is correct condition, press the start/stop button to proceed the next step. If the result is defective condition, press the reverse stitch button to proceed the next step.	LCD displays "10" and "Slide".  Buzzer sounds and "◀" mark appears at the leftmost position.  Buzzer sounds and "▶" mark appears at the rightmost position.	Buzzer does not sound. The "◀▶" marks appears in opposite way. The "◀▶" marks does not appear. –REMEDY– Replace the circuit board A.
11) DC MOTOR	Press the needle up/down button. If the result is correct condition, press the start/stop button to proceed the next step. If the result is defective condition, press the reverse stitch button to proceed the next step.	LCD displays "11" and "DC".  Machine runs slow, then fast, and the needle bar stops at its highest position.	The machine motor does not start. The motor runs unstable. –REMEDY– Replace the DC motor. Replace the circuit board A.

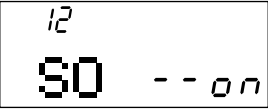
Diagnosis test

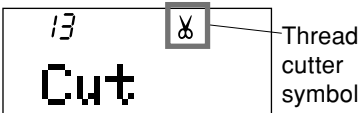
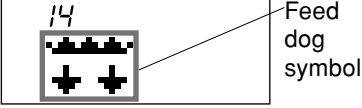
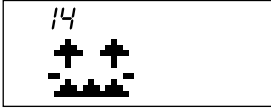
STEP AND ITEMS TO CHECK	PROCEDURE	CORRECT CONDITION	DEFECTIVE CONDITION
12) THREAD TENSION RELEASE SOLENOID	Lower the presser foot. Press the needle up/down button. If the result is correct condition, press the start/stop button to proceed the next step. If the result is defective condition, press the reverse stitch button to proceed the next step.	LCD displays "12", "SO" and "--off". Press the needle up/down button to switch the solenoid on or off. [ON] Buzzer sounds and the thread tension disk opens, and LCD displays "--on" while the thread tension disk opens. The thread tension disk will be closed automatically 5 seconds after the thread tension released.  [OFF] Buzzer sounds and the thread tension disc closes, and LCD displays "--off". 	The Thread tension disk does not open. -REMEDY- Replace the solenoid. Replace the circuit board A.
13) THREAD CUTTER MOTOR, THREAD CUTTER SOLENOID	Turn the handwheel toward you to raise the needle bar at its highest position. Press the needle up/down button. If the result is correct condition, press the start/stop button to proceed the next step. If the result is defective condition, press the reverse stitch button to proceed the next step.	LCD displays "13" and "Cut". The thread cutter symbol will blink, and thread cutter motor will be initialized. 	Thread cutter motor does not work. LCD displays "E4". -REMEDY- Replace the thread cutter motor. Adjust the sensor plate position. Replace the printed circuit board A. Thread cutter symbol does not change.
13) FEED DOG	Turn the drop feed lever to the right. Turn the drop feed lever to the left. If the result is correct condition, press the start/stop button to proceed the next step. If the result is defective condition, press the reverse stitch button to proceed the next step.	LCD displays "14" and feed dog symbol. When the drop feed lever is shifted away from you, LCD displays as Fig. 1. Fig. 1  When the drop feed lever is shifted toward you, LCD displays as Fig. 2. Fig. 2 	Buzzer does not sound. -REMEDY- Replace the drop feed dog lever unit. Replace the printed circuit board A. LCD does not change. LCD displays "PSerr".

Diagnosis test

STEP AND ITEMS TO CHECK	PROCEDURE	CORRECT CONDITION	DEFECTIVE CONDITION
14) NEEDLE PLATE	<p>Attach the needle plate. Attach the needle plate for straight stitch.</p> <p>If the result is correct condition, press the start/stop button to proceed the next step.</p> <p>If the result is defective condition, press the reverse stitch button to proceed the next step.</p>	<p>LCD displays "15".</p> <p>When the needle plate is attached to the machine, LCD displays "PSZ".</p> <div style="border: 1px solid black; padding: 5px; text-align: center;"> </div> <p>When the needle plate for straight stitch is attached to the machine, LCD displays "PSS".</p> <div style="border: 1px solid black; padding: 5px; text-align: center;"> </div> <p>When nothing is attached to the machine, LCD displays "15" only.</p> <div style="border: 1px solid black; padding: 5px; text-align: center;"> </div>	<p>Buzzer does not sound.</p> <p>-REMEDY- Replace the needle plate sensor. Replace the printed circuit board A.</p>

Buzzer sounds after few seconds when the self-diagnostic test has been finished.
The test result has been determined.

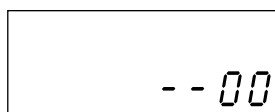

CORRECT:

Buzzer sounds and LCD displays "00"



DEFECTIVE:

Caution buzzer sounds and LCD displays the defective part number. Refer to page 31-35 and fix the defective part.

The defective part number.
See page 31-35 "Steps and items" section.

Turn the power switch off when the self-diagnostic test is finished.

TO DISPLAY THE VERSION OF THE PROGRAM

While pressing the needle up/down and lock stitch buttons, turn the power switch on.
The LCD screen display "----".

Press "2" on the touch panel.

Press the Start/stop button once to display the version of the program.

PARTS LIST

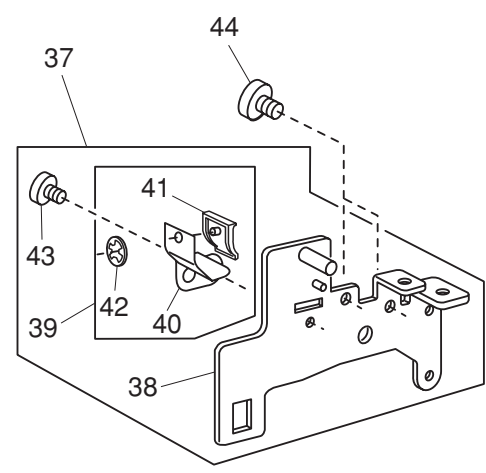
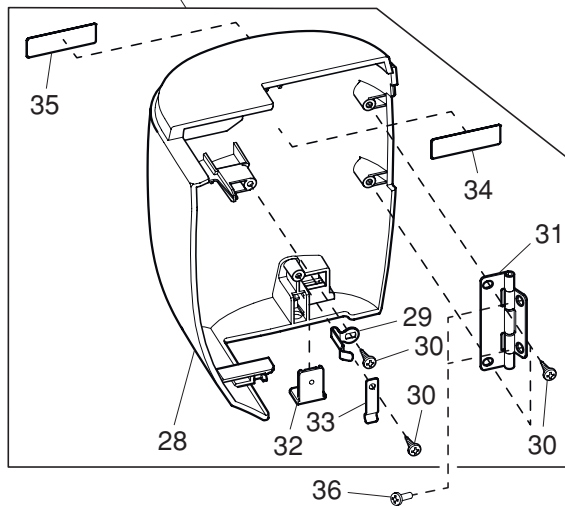
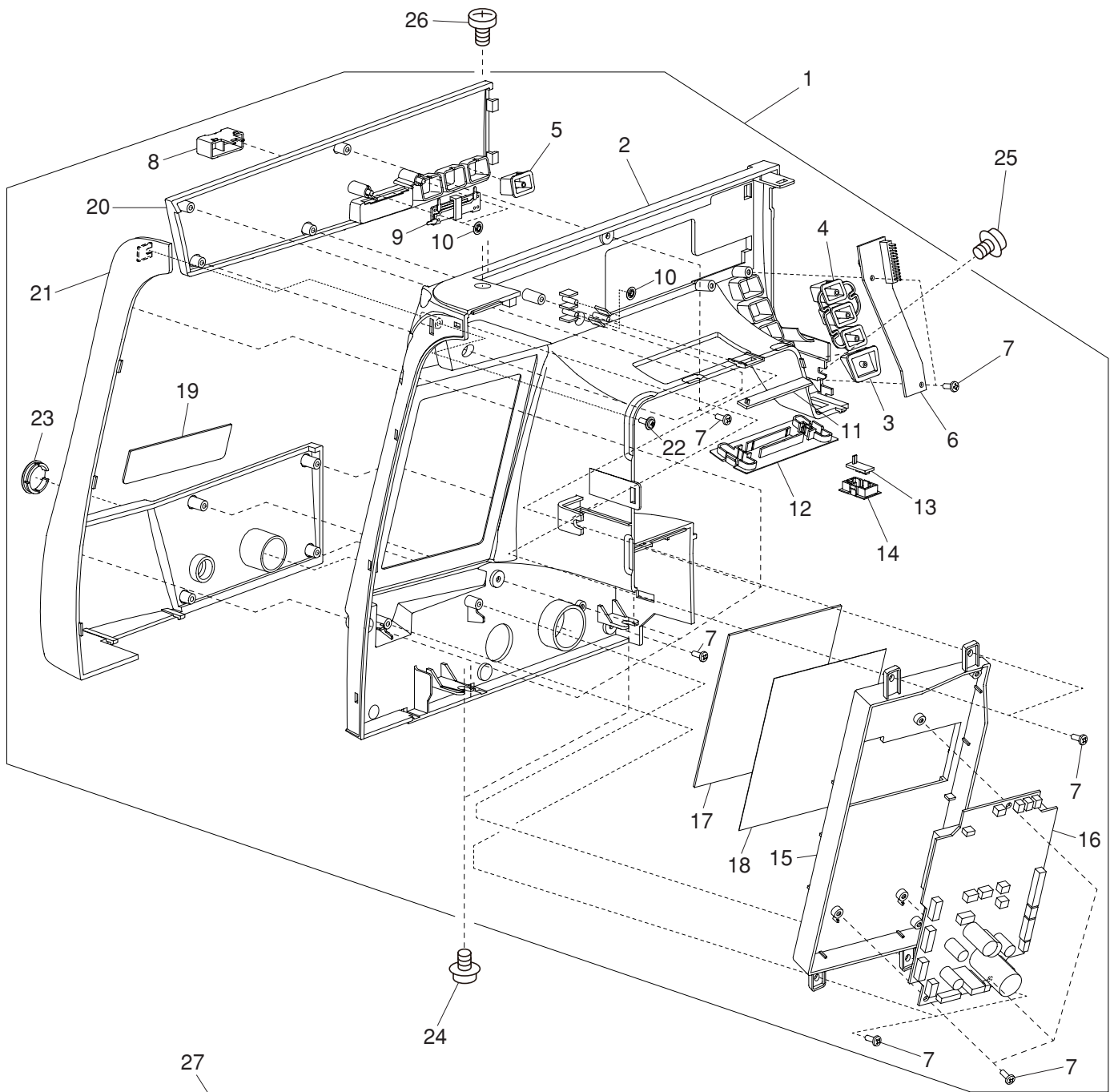

PARTS LIST

KEY NO.	PARTS NO.	DESCRIPTION
1	863608003	Front cover (unit)
2	863016008	Front cover
3	863017A01	Start/stop button
4	863018A01	Function button 1
5	863019A01	Function button 2
6	861510207	Printed circuit board F (unit)
7	000120203	Setscrew 3x8 (B)
8	863020005	Speed control slider
9	653507288	Slide volume (unit)
10	000014306	Snap ring CS-3
11	858502309	Printed circuit board L1 (unit)
12	858106000	LED cover 2
13	859525909	Printed circuit board L2 (unit)
14	860167006	Lamp cover 2
15	863021006	Printed circuit board A case
16	858542116	Printed circuit board A
17	852524000	Touch panel (unit)
18	863022A01	Touch panel sheet
19	863023A01	LCD panel
20	863024A01	Decorative plate 1
21	863025A01	Decorative plate 2
22	000149301	Flange head screw
23	859216007	Cap
24	000115205	Setscrew TP 4x6
25	000114710	Setscrew TP 3x6
26	000081005	Setscrew 4x8
27	863605000	Face plate (unit) (JAI)
	863605103	Face plate (unit) (JCA)
	863605206	Face plate (unit) (JA, JEBV)
28	863010A01	Face plate
29	850013005	Face plate spring
30	000161206	Setscrew 3x10 (B)
31	851503103	Face plate hinge (unit)
32	840602006	Thread cutter (unit)
33	859233000	Spring
34	830312016	Caution sticker (JAI)
	100045000	Caution sticker (JCA)
35	100517008	Caution sticker (JCA)
36	000081119	Setscrew 4x6
37	861612004	Carrying handle supporter (unit)
38	861024003	Carrying handle supporter
39	861613005	Spring (unit)
40	861073007	Spring
41	861074008	Spring cap
42	000017701	Snap ring CS-3.5
43	000101116	Setscrew 3x4
44	000081005	Setscrew 4x8

PARTS LIST

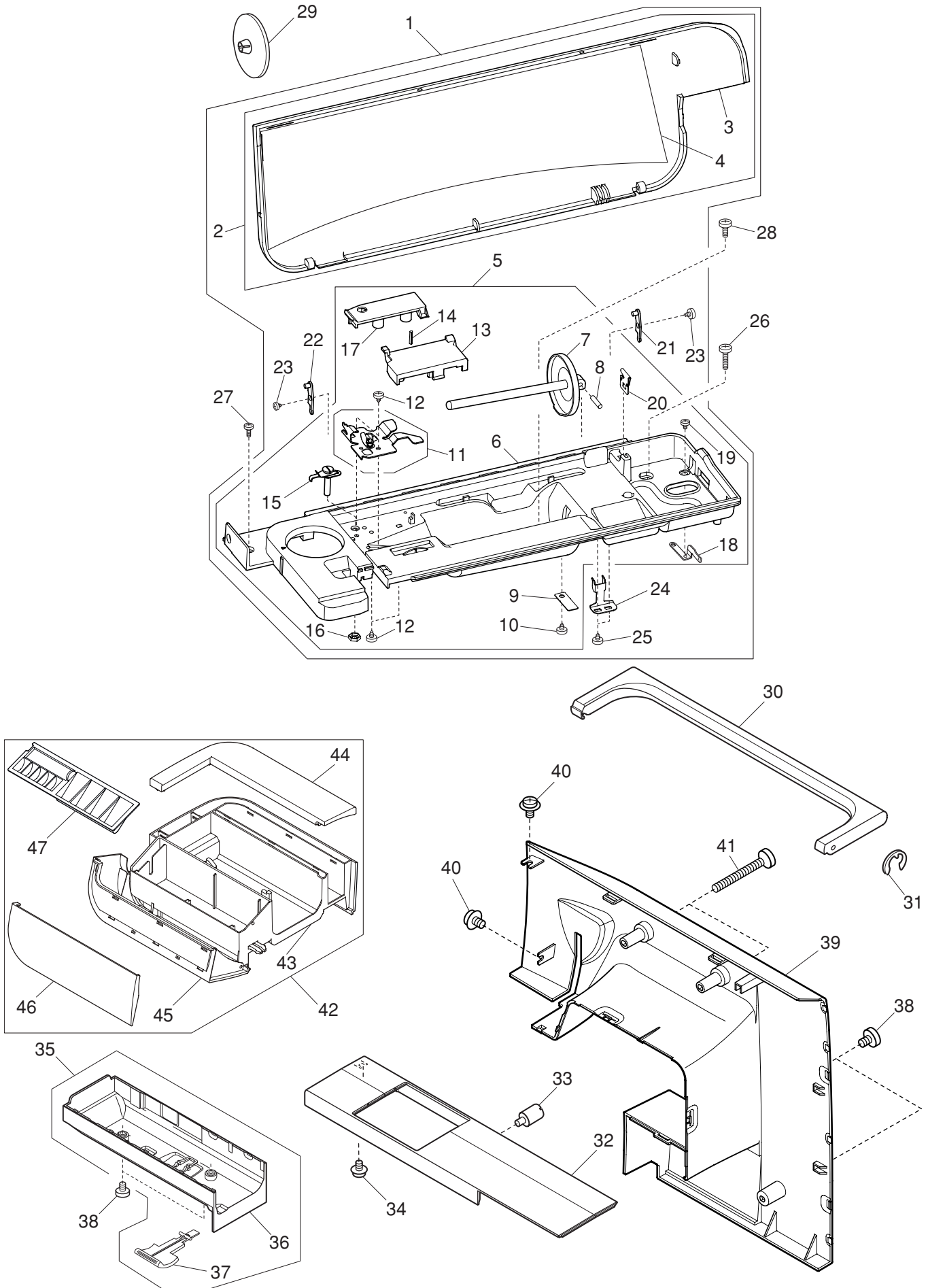

PARTS LIST

KEY NO.	PARTS NO.	DESCRIPTION
1	863602007	Top cover (whole unit)
2	863603008	Top cover (unit)
3	863007006	Top cover
4	863008A01	Quick reference chart
5	863604009	Top cover body (unit)
6	863009008	Top cover body
7	859052003	Spool pin
8	822017002	Spool pin shaft
9	822018003	Spool pin spring
10	000107204	Setscrew 3x12 (B)
11	859541004	Thread guide (unit)
12	000120203	Setscrew 3x8 (B)
13	859648002	Thread guide cover (unit)
14	000020202	Spring pin
15	830503005	Bobbin winder thread guide (unit)
16	000160102	Adjustable lock nut 4
17	830011001	Bobbin winder thread guide cover
18	861099009	Bobbin winder stopper
19	000103819	Setscrew 3x5
20	830505007	Thread cutter (unit)
21	858023002	Top cover hinge (right)
22	858023105	Top cover hinge (left)
23	000161206	Setscrew 3x10 (B)
24	859137003	Top cover hinge (right)
25	000120203	Setscrew 3x8 (B)
26	000104119	Setscrew 4x20
27	000066705	Setscrew 3x8
28	000170507	Setscrew 4x12
29	822020503	Spool holder
30	861019005	Carrying handle
31	000001609	Snap ring E-5
32	861007206	Free arm cover
33	858165100	Pin
34	000114710	Setscrew TP 3x6
35	861604003	Bed cover (unit)
36	861008001	Bed cover
37	859040008	Lever
38	000081005	Setscrew 4x8
39	863002A01	Rear cover
40	000115205	Setscrew TP 4x6
41	000093402	Setscrew 4x40
42	863613A01	Extension table (unit)
43	863003002	Extension table
44	863004003	Extension table cover
45	863005004	Extension table lid
46	863006005	Extension table lid cover
47	861012008	Foot tray

PARTS LIST

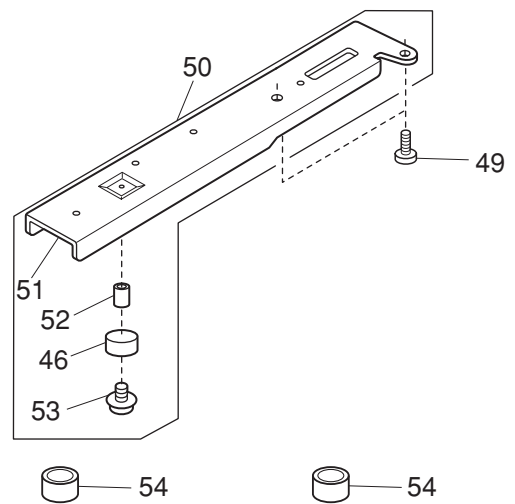
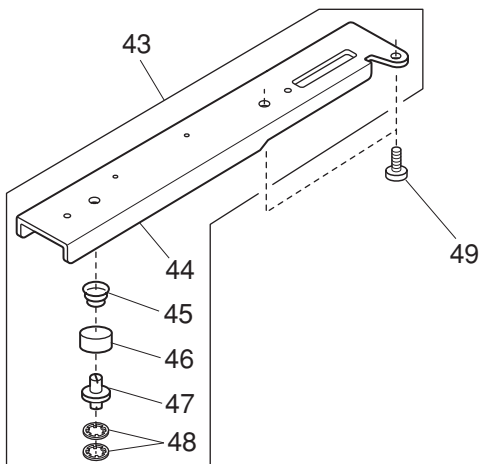
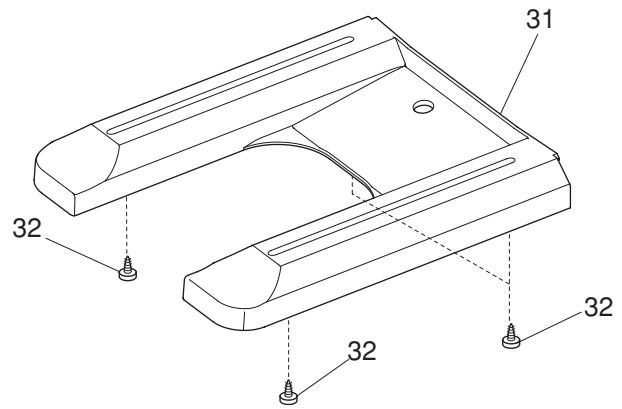
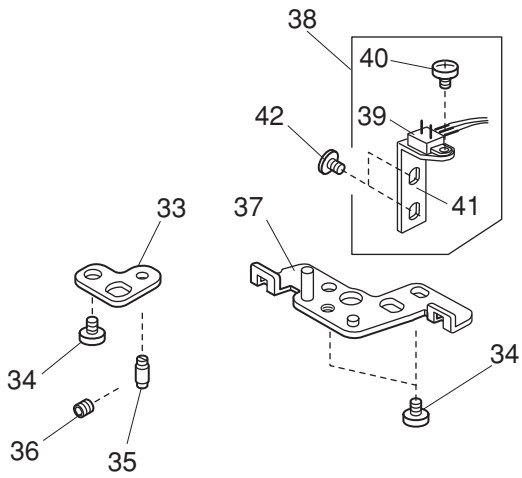
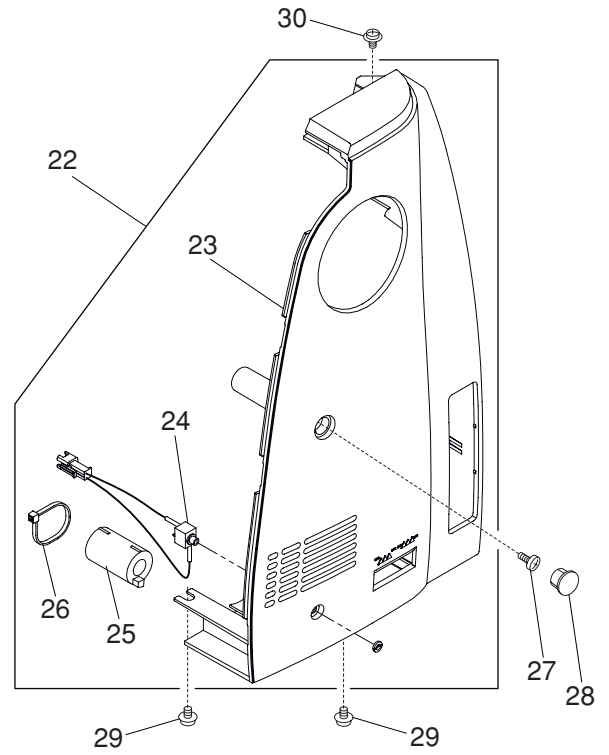
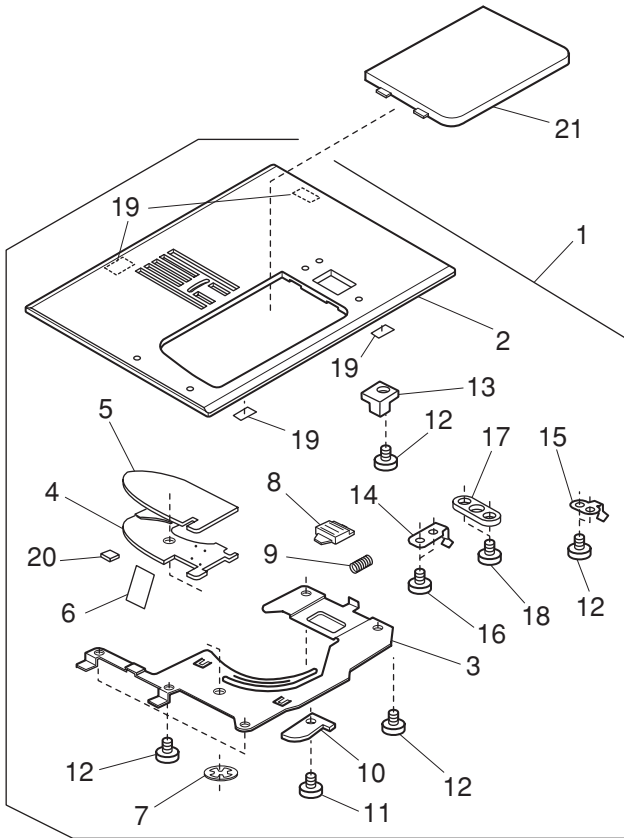

PARTS LIST

KEY NO.	PARTS NO.	DESCRIPTION
1	861606005	Needle plate (unit)
2	861013010	Needle plate
3	861014000	Hook cover plate supporter
4	809134005	Hook cover plate supporter base
5	809135006	Guide holder
6	809137008	Cutter
7	000014306	Snap ring CS-3
8	825016000	Hook cover plate release button
9	825017001	Spring
10	809044203	Rotation stopper
11	000097613	Setscrew 2x4
12	820374004	Setscrew 2x2.3
13	859046004	Needle plate sensor block
14	859047016	Spring
15	859245005	Spring 2
16	000169709	Setscrew 2x2.3
17	859271000	Guide plate
18	000102807	Setscrew 2x4
19	859272104	Rubber sheet
20	861152001	Felt
21	809136100	Hook cover plate
22	863611102	Belt cover (unit) (JAI, JCA)
	863611009	Belt cover (unit) (JA, JEBV)
23	863028003	Belt cover
	767541006	Jack cord (unit) (JAI, JCA)
24	767541202	Jack cord (unit) (JA, JEBV)
25	863504008	Ferrite core (JA, JEBV)
26	000053101	Cord binder (JA, JEBV)
27	000081005	Setscrew 4x8
28	745033002	Cap
29	000115205	Setscrew TP 4x6
30	000115009	Setscrew TP 3x8
31	863001000	Base cover
32	000161206	Setscrew 3x10 (B)
33	860003025	Needle plate nut set plate
34	810220106	Setscrew
35	859270009	Needle plate positioning pin
36	000111201	Hexagonal socket screw 4x4
37	859247018	Needle plate adjusting plate
38	859671107	Needle plate sensor (unit)
39	859524104	Switch (unit)
40	755096004	Setscrew
41	859246006	Switch set plate
42	000193001	Setscrew TP 4x6
43	861601000	Arm sole (front side) (unit)
44	861002005	Arm sole (front side)
45	858162004	Spring
46	605074008	Rubber foot
47	820350004	Adjusting screw
48	000014409	Snap ring CS-8
49	000100702	Setscrew 6x10
50	861603002	Arm sole (rear side) (unit)
51	861003006	Arm sole (rear side)
52	000141107	Bushing
53	000119106	Setscrew TP 4x10
54	647009002	Rubber foot

PARTS LIST

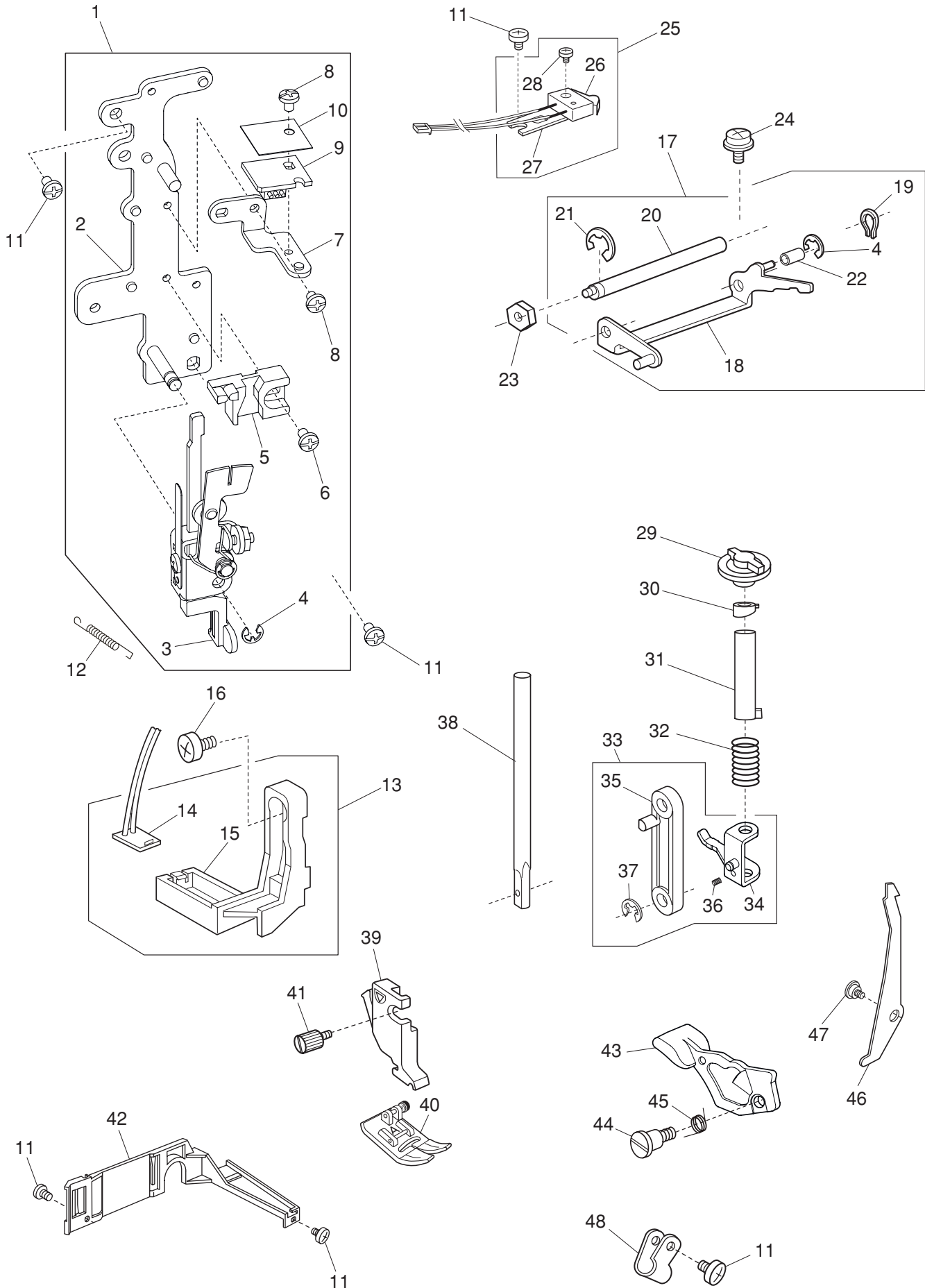

PARTS LIST

KEY NO.	PARTS NO.	DESCRIPTION
1	863606001	Front bracket (unit)
2	861030013	Front bracket
3	843625406	Buttonhole lever (unit)
4	000002105	Snap ring E-3
5	830057021	Buttonhole lever guide
6	000103808	Setscrew 3x5
7	861031003	Sensor base plate
8	000101105	Setscrew 3x4
9	852502312	Printed circuit board G1 (unit)
10	853028002	Insulation sheet
11	000081005	Setscrew 4x8
12	844038018	Needle bar supporter spring
13	861665404	LED cover (unit)
14	859525806	Printed circuit board L2 (unit)
15	859232021	LED cover
16	000078319	Setscrew 3x6
17	861616101	Presser foot actuator arm (unit)
18	861035007	Presser foot actuator arm
19	000014605	Snap ring 6
20	830060005	Presser foot actuator arm
21	000001609	Snap ring E-5
22	861034006	Bushing
23	000061205	Nut 4
24	000115629	Setscrew TP 4x8
25	861617009	Presser foot lifter switch (unit)
26	652520099	Micro switch (unit)
27	861029008	Micro switch set plate
28	000102900	Setscrew 2x8
29	858136102	Presser foot pressure adjusting dial
30	858155004	Presser foot pressure adjusting cam
31	858028007	Presser bar bushing
32	861026005	Presser bar spring
33	863614002	Presser bar supporter (unit)
34	863012004	Presser bar supporter
35	861028007	Presser bar link
36	000111500	Hexagonal socket screw 4x8
37	000002507	Snap ring E-4
38	827021200	Presser bar
39	859801005	Presser foot holder (unit)
40	859802006	Zigzag foot (unit)
41	858274000	Thumbscrew
42	861078002	Cord guide
43	863011003	Presser foot lifter lever
44	859028000	Setscrew
45	859029001	Spring
46	861067008	Tension release lever
47	859273002	Setscrew
48	000188601	Nylon clip

PARTS LIST

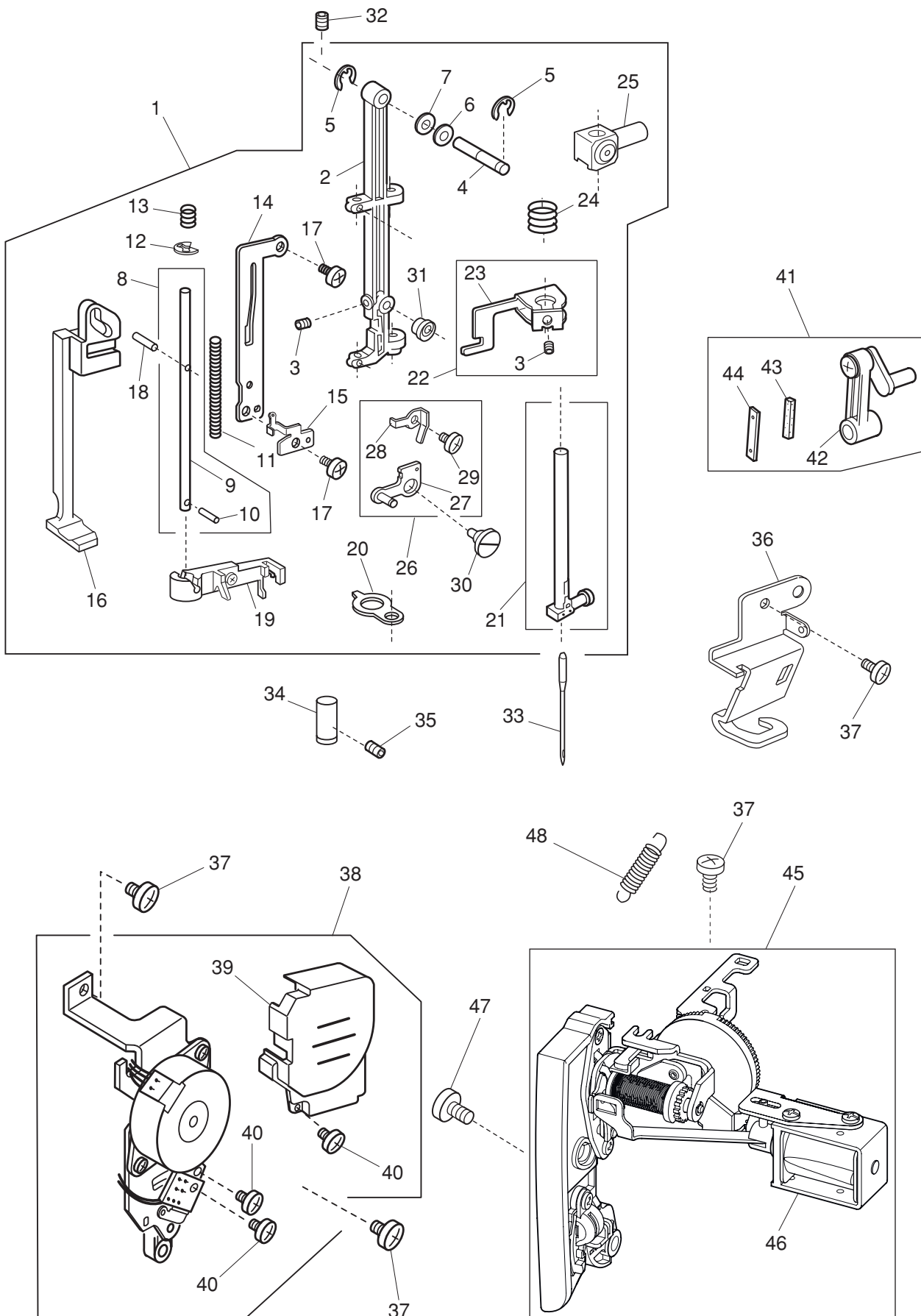

PARTS LIST

KEY NO.	PARTS NO.	DESCRIPTION
1	861664001	Needle bar supporter (unit)
2	846047005	Needle bar supporter
3	000111902	Hexagonal socket screw 3x4
4	735144006	Needle bar supporter pin
5	000002507	Snap ring E-4
6	000070609	Washer 6
7	673022002	Washer
8	846612100	Threader shaft (unit)
9	846048028	Threader shaft
10	000003508	Knock pin
11	842090001	Needle threader spring
12	000002105	Snap ring E-3
13	842096007	Threader lever spring
14	842091002	Threader guide plate
15	844036038	Threader lever plate
16	859111001	Threader lever
17	000078319	Setscrew 3x6
18	000125105	Pin
19	846588014	Threader guard plate (unit)
20	829027006	Supporter guide plate
21	859647001	Needle bar (unit)
22	861610002	Threader position setting plate (unit)
23	861052000	Threader position setting plate
24	858172007	Needle bar connecting stud spring
25	846515009	Needle bar connecting stud (unit)
26	861630008	Zigzag width rod (unit)
27	808015006	Zigzag width rod
28	827088009	Zigzag width rod spring
29	820373003	Setscrew
30	678084007	Eccentric pin
31	808074003	Washer
32	000111201	Hexagonal socket screw 4x4
33	647814031	Needle HA1-14
34	827083004	Supporter guide pin
35	000216805	Hexagonal socket screw 3x3
36	861004007	Arm thread guide
37	000081005	Setscrew 4x8
38	861629004	Zigzag width motor (unit)
39	861055003	Motor cover
40	000101105	Setscrew 3x4
41	846615103	Needle bar crank (unit)
42	843543007	Needle bar crank pin (unit)
43	650040005	Felt
44	650041006	Spring
45	863607002	Thread tension (unit)
46	834604308	Solenoid (unit)
47	000101703	Setscrew 4x12
48	850212017	Spring

PARTS LIST

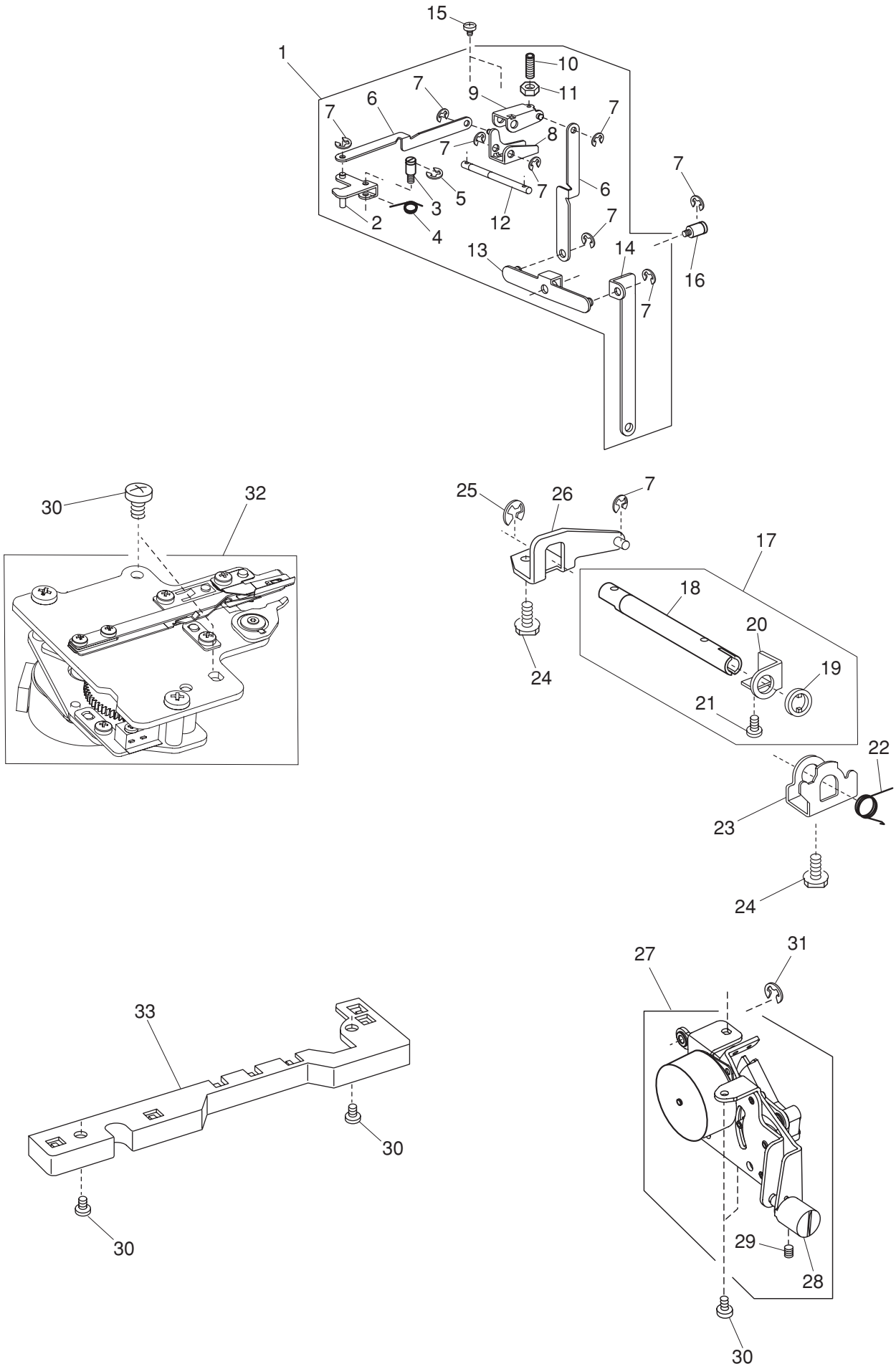

PARTS LIST

KEY NO.	PARTS NO.	DESCRIPTION
1	861633001	Knee lifter link (unit)
2	861058006	Knee lifter link (1)
3	861059007	Knee lifter link (1) shaft
4	861065006	Knee lifter link (1) spring
5	000001609	Snap ring E-5
6	861060001	Knee lifter rod (1)
7	000002507	Snap ring E-4
8	860053008	Knee lifter link (2)
9	861061002	Knee lifter link (3)
10	000196406	Hexagonal socket screw 4x25
11	000061205	Nut 4
12	861062003	Knee lifter link (2) shaft
13	861063004	Knee lifter middle link
14	861064005	Knee lifter link (4)
15	000103303	Setscrew 3.5x12
16	686063005	Setscrew
17	861632000	Knee lifter shaft (unit)
18	861057005	Knee lifter shaft
19	846297002	Stopper
20	861072006	Stopper plate
21	000101105	Setscrew 3x4
22	858091001	Knee lifter stopper spring
23	861154003	Knee lifter stopper
24	000138503	Hexagonal socket screw 5x12
25	000002208	Snap ring E-9
26	861066007	Knee lifter shaft arm
27	861628106	Feed motor (unit)
28	859215006	Feed balancing dial
29	000110200	Hexagonal socket screw 4x4 WP
30	000081005	Setscrew 4x8
31	000002105	Snap ring E-3
32	861631009	Automatic thread cutter (unit)
33	861077001	Cord guide (Free arm)

PARTS LIST

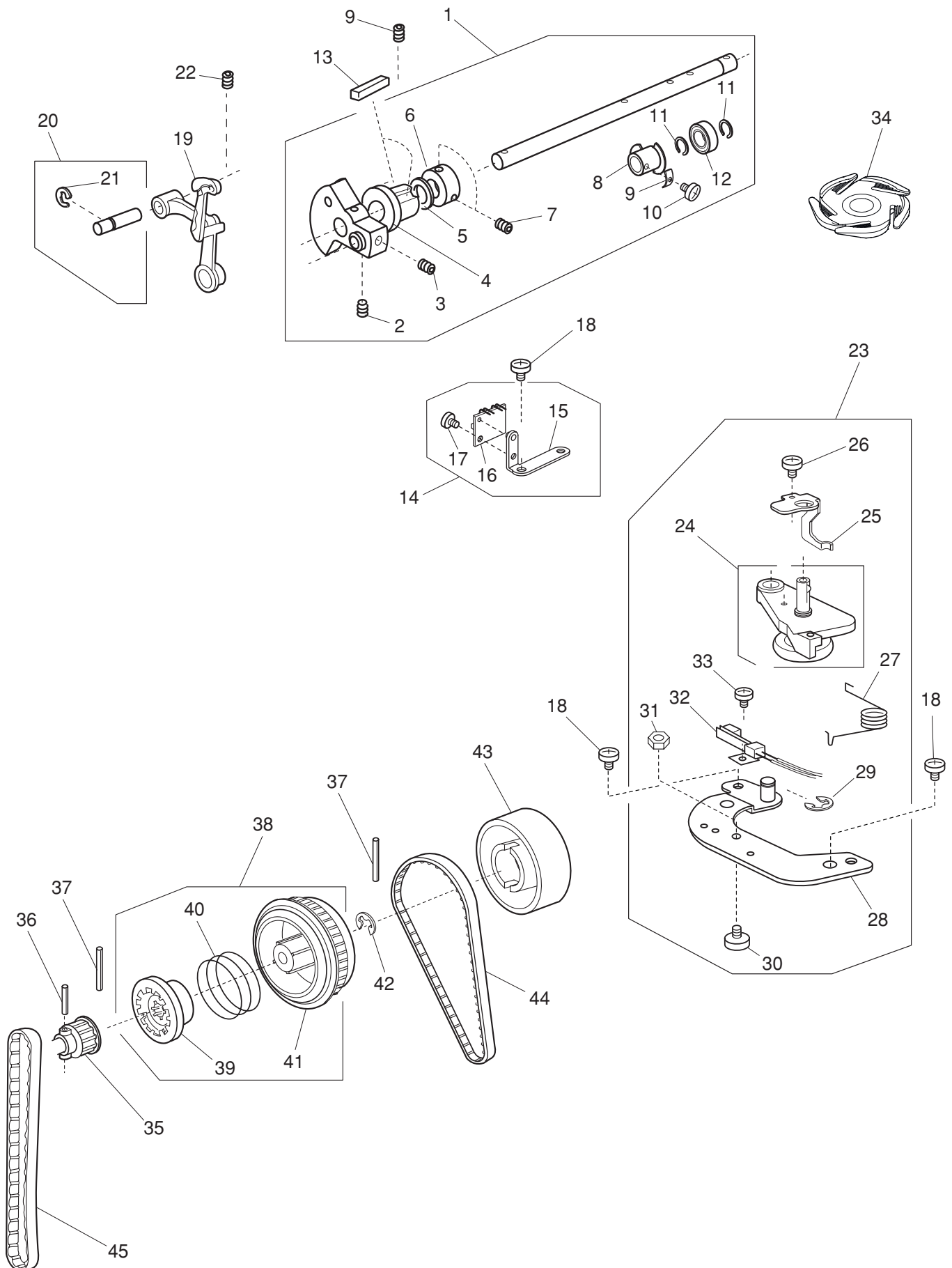

PARTS LIST

KEY NO.	PARTS NO.	DESCRIPTION
1	861619104	Upper shaft (unit)
2	000111706	Hexagonal socket screw 5x8
3	000110901	Hexagonal socket screw 5x4
4	670079201	Upper shaft front bushing
5	000040105	Washer
6	767077006	Ring
7	000111304	Hexagonal socket screw 5x5
8	859055006	Upper shaft shield plate
9	859033008	Washer
10	000080406	Setscrew 3x10
11	000032702	Snap ring crescent
12	767178101	Ball bearing 6901ZZ
13	731312005	Felt
14	861620108	Upper shaft sensor (unit)
15	861039001	Sensor set plate
16	807505201	Printed circuit board P (unit)
17	000101105	Setscrew 3x4
18	000081005	Setscrew 4x8
19	820511108	Thread take-up lever (unit)
20	650626001	Thread take-up lever pin (unit)
21	000002806	Snap ring E-6
22	000111201	Hexagonal socket screw 4x4
23	861636200	Bobbin winder (unit)
24	861503001	Bobbin winder (unit)
25	861096006	Clutch lever
26	000120203	Setscrew 3x8 (B)
27	861091001	Bobbin winder arm spring
28	861092002	Bobbin winder set plate
29	000001609	Snap ring E-5
30	861153002	Bobbin winder stopper screw
31	000063104	Nut 3-2-5.5
32	856512203	Leaf switch (unit)
33	000081706	Setscrew 2.5x5
34	862647001	Thread cutter holder (unit)
35	858052000	Upper shaft gear
36	000004303	Pin 3x20
37	000024206	Pin 3x30
38	858647008	Belt wheel (unit)
39	858053001	Clutch ring
40	502065004	Clutch spring
41	858054002	Belt wheel
42	000030009	Snap ring E-10
43	858055106	Handwheel
44	846098001	Timing belt 178
45	858118005	Timing belt 168

PARTS LIST

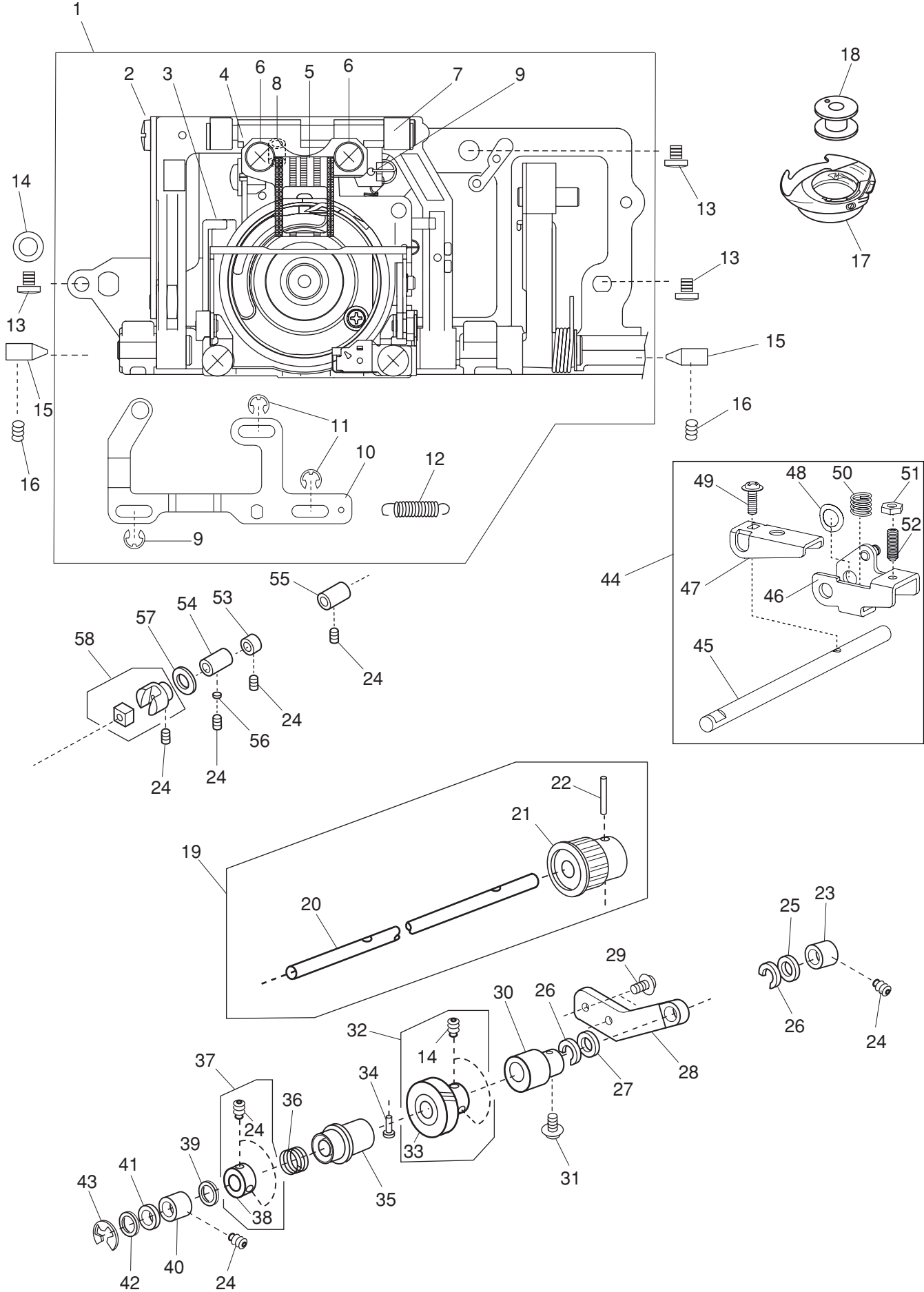

PARTS LIST

KEY NO.	PARTS NO.	DESCRIPTION
1	861625103	Feed rock shaft (whole unit)
2	846629100	Feed rock shaft (unit)
3	861626104	Hook race (unit)
4	859639000	Feed base (unit)
5	859113003	Feed dog
6	000104005	Setscrew 3.5x8
7	825099007	Feed base shaft
8	000111407	Hexagonal socket screw 4x6
9	825103005	Feed base spring
10	858138001	Drop plate
11	000002105	Snap ring E-3
12	661018008	Spring
13	000081005	Setscrew 4x8
14	000070506	Washer 4
15	738055008	Straight pin
16	000111304	Hexagonal socket screw 5x5
17	858570009	Bobbin holder (unit)
18	102261103	Bobbin
19	861621006	Lower shaft (unit)
20	861040005	Lower shaft
21	650073007	Lower gear
22	000004200	Pin 3x18
23	650079003	Lower shaft bushing (rear)
24	000111201	Hexagonal socket screw 4x4
25	822070003	Felt (1)
26	822112008	Felt holder (1)
27	861051009	Felt
28	858058006	Lower shaft supporter
29	000115700	Setscrew TP 4x10
30	846379009	Feed cam
31	000149600	Setscrew 3x14
32	850687006	Lower shaft gear (unit)
33	650955002	Lower shaft gear
34	820161006	Feed lifting pin
35	846103000	Feed lifting cam
36	825093001	Feed lifting cam spring
37	820672005	Lower shaft ring (unit)
38	820166001	Lower shaft ring
39	000038502	Washer
40	858060001	Lower shaft bushing (front)
41	735143005	Felt
42	858177002	Lower shaft washer
43	000002806	Snap ring E-6
44	861627002	Feed shaft (unit)
45	861048003	Feed shaft
46	858129009	Feed arm (1)
47	858130003	Feed arm (2)
48	810207004	Washer
49	000201302	Setscrew TP 3x10
50	589040002	Spring
51	000160102	Adjustable lock nut 4
52	000177401	Hexagonal socket screw 4x12
53	820387000	Ring
54	625144002	Feed shaft bushing (front)
55	650092002	Feed shaft bushing (rear)
56	650175000	Washer
57	823110009	Felt
58	625508008	Feed regulator (unit)

PARTS LIST

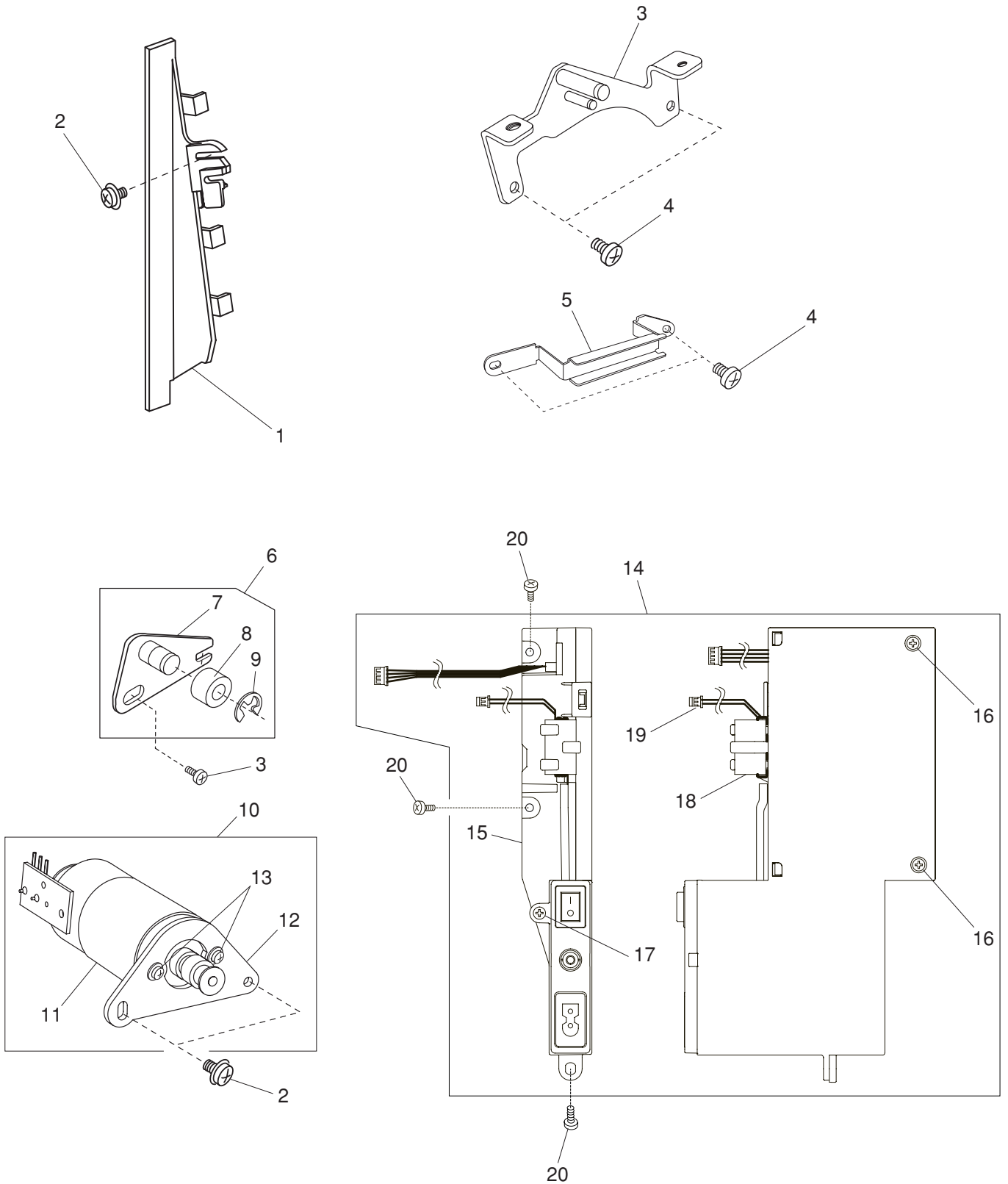

PARTS LIST

KEY NO.	PARTS NO.	DESCRIPTION
1	858145012	Cord guide plate
2	000115607	Set screw TP 4X8
3	861075009	Carrying handle supporter (rear)
4	000081005	Setscrew 4x8
5	861089006	Cord guide
6	860608004	Idler (unit)
7	860021007	Idler base
8	625217100	Idler
9	000002806	Snap ring E-6
10	858639100	DC motor (unit)
11	843518807	DC motor (unit)
12	858117004	DC motor bracket
13	000115009	Set screw TP 3X8
14	863612103	Switching power supply (unit) (JAI, JCA)
	863612000	Switching power supply (unit) (JA, JEBV)
15	862004000	Switching power supply case
16	000119704	Setscrew 3x14 (B)
17	000161206	Setscrew 3x10 (B)
18	808108007	Ferrite core (JA, JEBV)
19	863505009	TRS connector cord
20	000103509	Setscrew 4x10

PARTS LIST

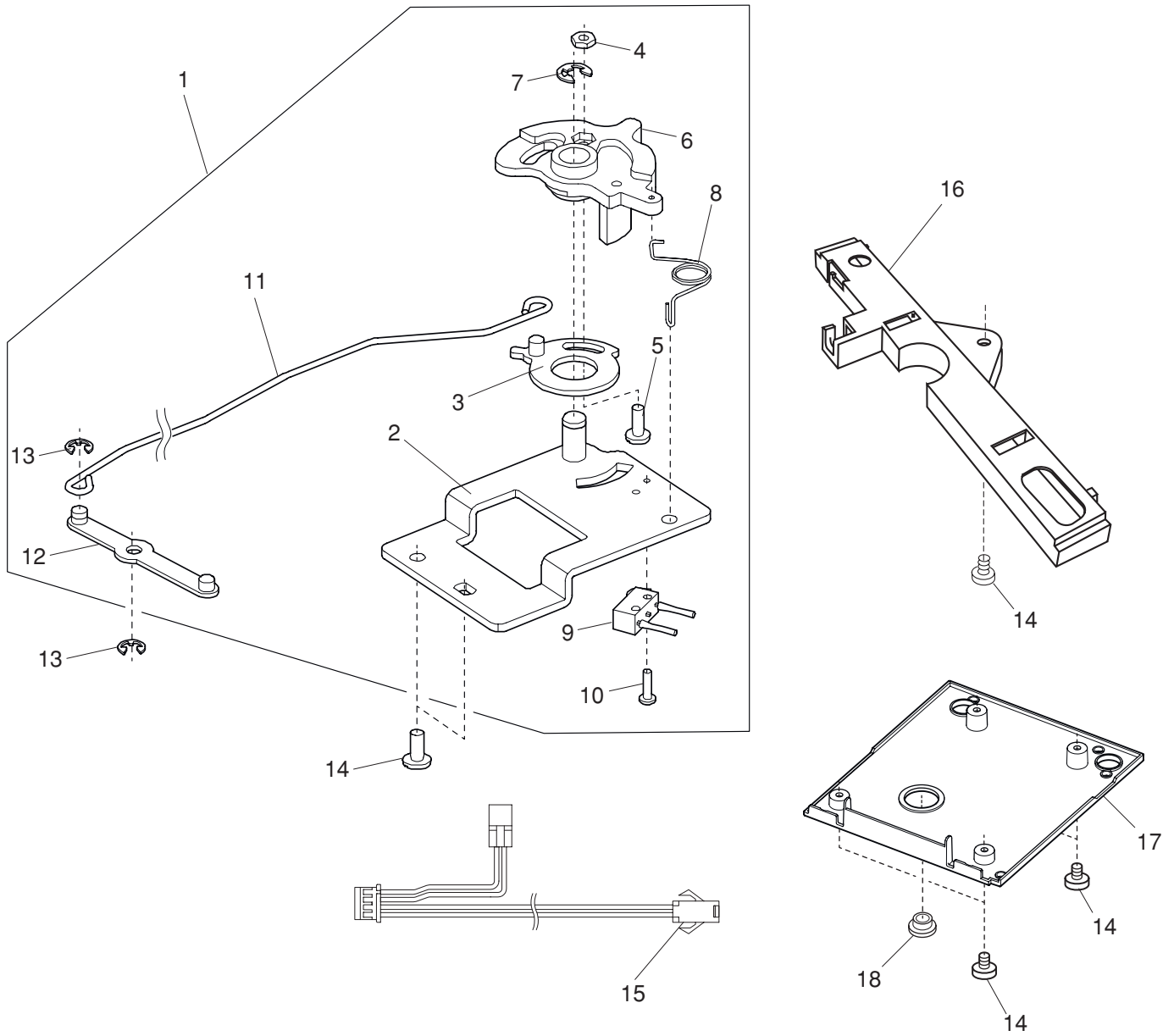

PARTS LIST

KEY NO.	PARTS NO.	DESCRIPTION
1	863610008	Feed dog drop lever (unit)
2	863026001	Feed dog drop lever base
3	858142008	Feed dog drop lever connecting plate
4	000061803	Nut 3-3-5.5
5	000066705	Setscrew 3x8
6	858143009	Feed dog drop lever
7	000002507	Snap ring E-4
8	823119008	Spring
9	846513030	Micro switch (unit)
10	000102900	Setscrew 2x8
11	863027002	Rod
12	858139002	Drop connecting block
13	000002105	Snap ring E-3
14	000081005	Setscrew 4x8
15	863503007	Junction cable
16	858159019	Cord guide 2
17	863029004	Base plate
18	626045407	Cap

PARTS LIST

1

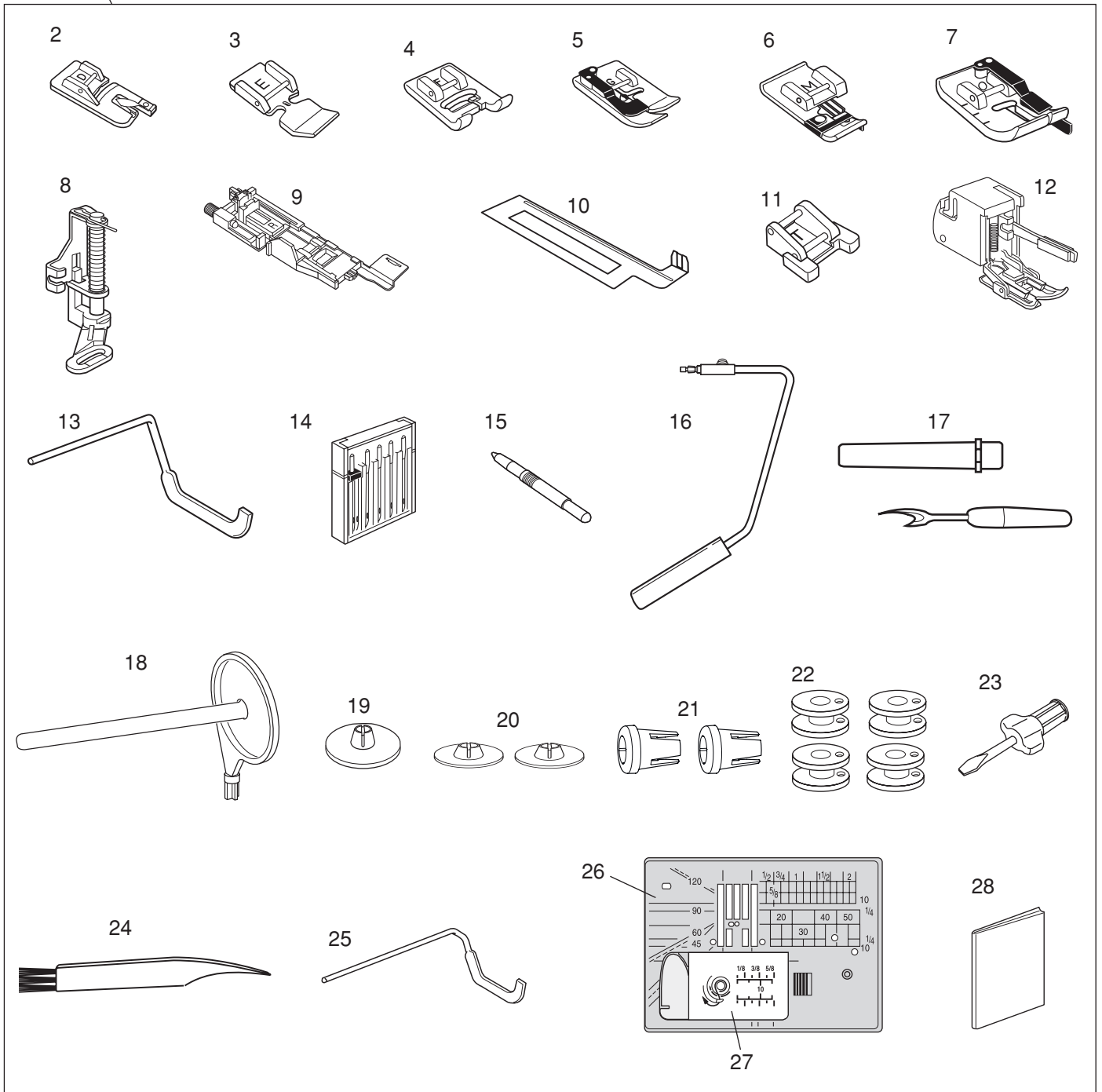

29

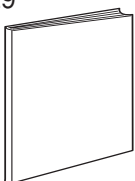

30

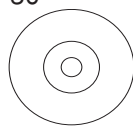

31

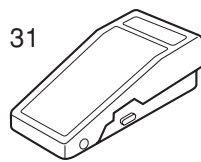

33

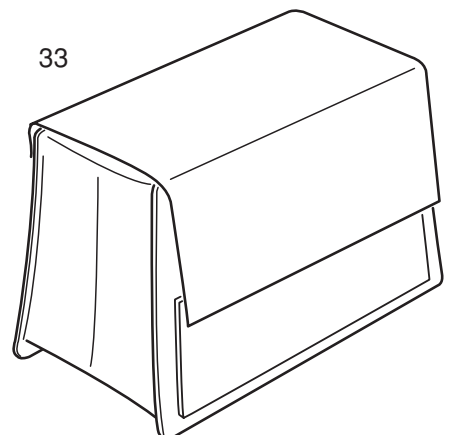

32 (JAI, JCA)

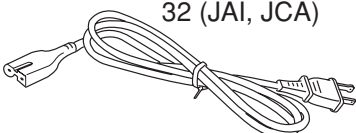

32 (JA)

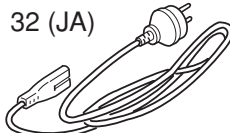

32 (JEBV)

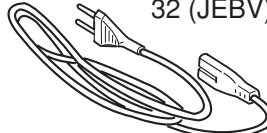

PARTS LIST

KEY NO.	PARTS NO.	DESCRIPTION
1	863870008	Accessories set
2	859804008	Rolled hem foot D
3	859805009	Zipper foot E
4	859806011	Satin stitch foot F
5	859807001	Blind hemming foot G
6	859810007	Overedge foot M
7	859814001	1/4" Seam foot O
8	859839002	Darning foot PD-H
9	862822013	Automatic buttonhole foot R
10	859832016	Stabilizer plate
11	859811008	Button sewing foot T
12	202137009	Even feed foot
13	214015007	Quilting bar
14	859856005	Needle case (unit)
15	860194002	Touch panel stylus
16	846417011	Knee lifter
17	647808009	Seam ripper (buttonhole opener)
18	809041004	Extra spool pin
19	822020503	Spool holder (large)
20	822019509	Spool holders (small)
21	862408008	Spool holders (special)
22	102261103	Bobbins
23	820832005	Screwdriver
24	802424004	Lint brush
25	755802001	Quilting guide bar
26	862817107	Straight stitch needle plate
27	809136100	Hook cover plate
28	858801002	Caution card
29	863800007	Instruction book (English)
	863800029	Instruction book (German)
	863800030	Instruction book (French)
	863800041	Instruction book (Dutch)
30	863801008	Instructional DVD
31	C-1036	Foot control
32	856519004	Power cable (JAI, JCA)
	830314018	Power cable (JA)
	830335004	Power cable (JEBV)
33	858802003	Cover